

**DELCORTE**  
**FITTINGS**

## PRODUCTS CATALOGUE

**SPECIALIST OF :**



- FORGED FITTINGS
  - BRANCH OUTLETS
  - API COUPLINGS  
& SPECIAL FORGINGS
- in all grades

**DELCORTE S.A.S**  
MAUBEUGE • FRANCE  
*Since 1924*

## I. HIGH PRESSURE DIVISION

### DIVISION HAUTE PRESSION ..... 3-46

- 1. Forged fittings (carbon, alloy, stainless steels, duplex, super duplex and nickel alloy) .....3-22  
*Raccords forgés (acier carbone, alliés, inoxydables)*
- 2. Branch outlets (carbon, alloy, stainless steels, duplex, super duplex and nickel alloy) .....23-42  
*Raccord de dérivations renforcés (acier carbone, alliés, inoxydables)*
- 3. Special forged pieces & butt weld fittings  
ASME B 16.9 (subsea & specific applications) .....43-46  
*Pièces spéciales de forge*

## II. API COUPLINGS DIVISION

### DIVISION MANCHONS PETROLIERS ..... 47-52

- API 5CT casing and tubing couplings ..... 48-51  
*Manchons tubing & casing API 5CT*
- API 5L line pipe couplings ..... 52  
*Manchons line pipe API 5L*

## III. LOW PRESSURE DIVISION

### DIVISION BASSE PRESSION ..... 53-62

- Wrought steel threaded fittings EN 10241 ..... 55-56  
*Raccords acier gaz suivant EN 10241*
- Pipe nipples and tubulars ..... 57  
*Mamelons en acier et pièces tubulaires*
- Steel couplings / sockets and fittings for fire fighting installations ..... 58-60  
*Manchons en acier et raccords pour installations anti-feu*

## IV. TECHNICAL INFORMATION

### INFORMATIONS TECHNIQUES ..... 63-74

- Materials requirements / pressure rating / thread standards /  
dimensions of SW fittings, weight list / pipe dimensions  
*Spécifications matières / pression de service / standards de filetage /  
dimensions des raccords à souder / liste de poids / dimensions de tube*



## I. HIGH PRESSURE DIVISION

### DIVISION HAUTEPRESSION

#### 1. Forged fittings (carbon, alloy, stainless steels, duplex, super duplex and nickel alloy)

*Raccords forgés (acier carbone, alliés, inoxydables)*



<b>90° ELBOW - COUDE 90°</b> .....	<b>5</b>
<b>45° ELBOW - COUDE 45°</b> .....	<b>5</b>
<b>TEE - CROSS - TÉ - CROIX</b> .....	<b>6</b>
<b>COUPLING - HALF-COUPLING - MANCHON - DEMI-MANCHON</b> .....	<b>6</b>
<b>CAP - BOUCHON FEMELLE</b> .....	<b>7</b>
<b>HEX HEAD PLUG - BOUCHON MÂLE TÊTE HEXAGONALE</b> .....	<b>7</b>
<b>HEX HEAD BUSHING - RÉDUCTION MÂLE-FEMELLE</b> .....	<b>8</b>
<b>SQUARE HEAD PLUG - BOUCHON MÂLE TÊTE CARRÉE</b> .....	<b>8</b>
<b>ROUND HEAD PLUG - BOUCHON MÂLE TÊTE RONDE</b> .....	<b>9</b>
<b>FEMALE-MALE REDUCER - RÉDUCTION FEMELLE-MÂLE</b> .....	<b>9</b>
<b>REDUCING HEXAGONAL NIPPLE - MAMELON RÉDUIT</b> .....	<b>10</b>
<b>REDUCING COUPLING - MANCHON RÉDUIT</b> .....	<b>10</b>
<b>HEXAGONAL NIPPLE - MAMELON</b> .....	<b>11</b>
<b>WELDING BOSS - BOSSAGE À SOUDER</b> .....	<b>11</b>
<b>90° STREET ELBOW - COUDE MÂLE-FEMELLE</b> .....	<b>12</b>
<b>UNION ELBOW - UNION TEE - COUDE UNION - TÉ UNION</b> .....	<b>12</b>
<b>FEMALE-FEMALE UNION - UNION FEMELLE-FEMELLE</b> .....	<b>13</b>
<b>MALE-FEMALE UNION - UNION MÂLE-FEMELLE</b> .....	<b>13</b>
<b>PIPE NIPPLE - MAMELON TUBE</b> .....	<b>14</b>
<b>SWAGE NIPPLE - SWEDGE NIPPLE</b> .....	<b>15</b>
<b>CODE USED IN MATERIAL LIST OF SWAGE NIPPLES</b> .....	<b>15</b>
<b>BOSS/COUplet - BOSSAGE - COUplet</b> .....	<b>16</b>
<b>ELBOW - COUDE</b> .....	<b>17</b>
<b>TEE - CROSS - TÉ - CROIX</b> .....	<b>17</b>
<b>COUPLING - HALF-COUPLING - MANCHON - DEMI-MANCHON</b> .....	<b>18</b>
<b>CAP - BOUCHON FEMELLE</b> .....	<b>18</b>
<b>REDUCING COUPLING - MANCHON RÉDUIT</b> .....	<b>19</b>
<b>WELDING BOSS - BOSSAGE À SOUDER</b> .....	<b>19</b>
<b>BOSS/COUplet - BOSSAGE - COUplet</b> .....	<b>20</b>
<b>REDUCING INSERT - RÉDUCTION MÂLE-FEMELLE</b> .....	<b>21</b>
<b>UNION - BULL PLUG - UNION - BULL PLUG</b> .....	<b>22</b>



## 90° ELBOW Coude 90°

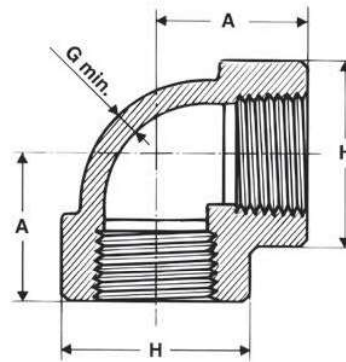

Class 3000 lbs. - 6000 lbs.  
Dimensions: ASME B 16.11  
Thread: ASME B 1.20.1

Nominal pipe size Diamètre nominal	3000						6000					
	A		H		G		A		H		G	
	inches	mm	inches	mm	inches	mm	inches	mm	inches	mm	inches	mm
1/4	0.97	25	1.00	25	0.130	3,30	1.12	28	1.31	33	0.260	6,60
3/8	1.12	28	1.31	33	0.138	3,51	1.31	33	1.50	38	0.275	6,98
1/2	1.31	33	1.50	38	0.161	4,09	1.50	38	1.81	46	0.321	8,15
3/4	1.50	38	1.81	46	0.170	4,32	1.75	44	2.19	56	0.336	8,53
1	1.75	44	2.19	56	0.196	4,98	2.00	51	2.44	62	0.391	9,93
1 1/4	2.00	51	2.44	62	0.208	5,28	2.38	60	2.97	75	0.417	10,59
1 1/2	2.38	60	2.97	75	0.219	5,56	2.50	64	3.31	84	0.436	11,07
2	2.50	64	3.31	84	0.281	7,14	3.25	83	4.00	102	0.476	12,09
2 1/2	3.25	83	4.00	102	0.301	7,65	3.75	95	4.75	121	0.602	15,29
3	3.75	95	4.75	121	0.348	8,84	4.19	106	5.75	146	0.655	16,64
4	4.50	114	6.00	152	0.440	11,18	4.50	114	6.00	152	0.735	18,67

5" and 6" Available on request (Forgings available from stock) Manufacturer standard

## 45° ELBOW Coude 45°

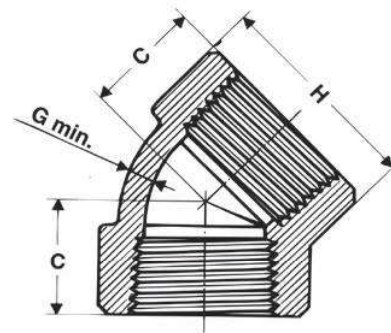

Class 3000 lbs. - 6000 lbs.  
Dimensions: ASME B 16.11  
Thread: ASME B 1.20.1

Nominal pipe size Diamètre nominal	3000						6000					
	C		H		G		C		H		G	
	inches	mm	inches	mm	inches	mm	inches	mm	inches	mm	inches	mm
1/4	0.75	19	1.00	25	0.130	3,30	0.88	22	1.31	33	0.260	6,60
3/8	0.88	22	1.31	33	0.138	3,51	1.00	25	1.50	38	0.275	6,98
1/2	1.00	25	1.50	38	0.161	4,09	1.12	28	1.81	46	0.321	8,15
3/4	1.12	28	1.81	46	0.170	4,32	1.31	33	2.19	56	0.336	8,53
1	1.31	33	2.19	56	0.196	4,98	1.38	35	2.44	62	0.391	9,93
1 1/4	1.38	35	2.44	62	0.208	5,28	1.69	43	2.97	75	0.417	10,59
1 1/2	1.69	43	2.97	75	0.219	5,56	1.72	44	3.31	84	0.436	11,07
2	1.72	44	3.31	84	0.281	7,14	2.06	52	4.00	102	0.476	12,09
2 1/2	2.06	52	4.00	102	0.301	7,65	2.50	64	4.75	121	0.602	15,29
3	2.50	64	4.75	121	0.348	8,84	3.12	79	5.75	146	0.655	16,64
4	3.12	79	6.00	152	0.440	11,18	3.12	79	6.00	152	0.735	18,67

5" and 6" Available on request (Forgings available from stock) Manufacturer standard

**TEE**  
**CROSS**  
Té  
Croix

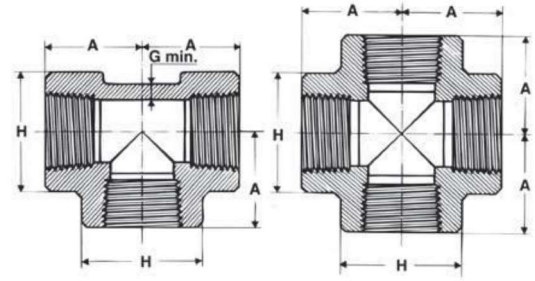

Class 3000 lbs. - 6000 lbs.  
Dimensions: ASME B 16.11  
Thread: ASME B 1.20.1

Nominal pipe size Diamètre nominal	3000						6000					
	A		H		G		A		H		G	
	inches	mm	inches	mm	inches	mm	inches	mm	inches	mm	inches	mm
1/4	0.97	25	1.00	25	0.130	3,30	1.12	29	1.31	33	0.260	6,60
3/8	1.12	29	1.31	33	0.138	3,51	1.31	33	1.50	38	0.275	6,98
1/2	1.31	33	1.50	38	0.161	4,09	1.50	38	1.81	46	0.321	8,15
3/4	1.50	38	1.81	46	0.170	4,32	1.75	44	2.19	56	0.336	8,53
1	1.75	44	2.19	56	0.196	4,98	2,00	51	2.44	62	0.391	9,93
1 1/4	2.00	51	2.44	62	0.208	5,28	2.38	60	2.97	75	0.417	10,59
1 1/2	2.38	60	2.97	75	0.219	5,56	2.50	64	3.31	84	0.436	11,07
2	2.50	64	3.31	84	0.281	7,14	3.25	83	4.00	102	0.476	12,09
2 1/2	3.25	83	4.00	102	0.301	7,65	3.75	95	4.75	121	0.602	15,29
3	3.75	95	4.75	121	0.348	8,84	4.19	106	5.75	146	0.655	16,64
4	4.50	114	6.00	152	0.440	11,18	4.50	114	6.00	152	0.735	18,67

5" and 6" Available on request (Forgings available from stock) Manufacturer standard  
Red. Tees & Red. Crosses – refer to page 69

**COUPLING**  
**HALF-COUPLING**  
Manchon  
Demi-manchon

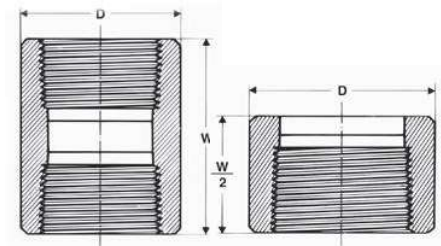

Class 3000 lbs. - 6000 lbs.  
Dimensions: ASME B 16.11  
Thread: ASME B 1.20.1

Nominal pipe size Diamètre nominal	3000				6000			
	W		D		W		D	
	inches	mm	inches	mm	inches	mm	inches	mm
1/4	1.38	35	0.75	19	1.38	35	1.00	25
3/8	1.50	38	0.88	22	1.50	38	1.25	32
1/2	1.88	48	1.12	28	1.88	48	1.50	38
3/4	2.00	51	1.38	35	2.00	51	1.75	44
1	2.38	60	1.75	44	2.38	60	2.25	57
1 1/4	2.62	67	2.25	57	2.62	67	2.50	64
1 1/2	3.12	79	2.50	64	3.12	79	3.00	76
2	3.38	86	3.00	76	3.38	86	3.62	92
2 1/2	3.62	92	3.62	92	3.62	92	4.25	108
3	4.25	108	4.25	108	4.25	108	5.00	127
4	4.75	121	5.50	140	4.75	121	6.25	159

5" and 6" Available on request (Forgings available from stock) Manufacturer standard

## CAP

### Bouchon femelle

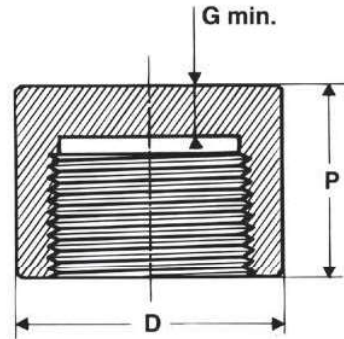

Class 3000 lbs. - 6000 lbs.  
Dimensions: ASME B 16.11  
Thread: ASME B 1.20.1

Nominal pipe size Diamètre nominal	3000						6000					
	P		D		G		P		D		G	
	inches	mm	inches	mm	inches	mm	inches	mm	inches	mm	inches	mm
1/4	1.00	25	0.75	19	0.19	4,8	1.06	27	1.00	25	0.25	6,4
3/8	1.00	25	0.88	22	0.19	4,8	1.06	27	1.25	32	0.25	6,4
1/2	1.25	32	1.12	28	0.25	6,4	1.31	33	1.50	38	0.31	7,9
3/4	1.44	37	1.38	35	0.25	6,4	1.50	38	1.75	44	0.31	7,9
1	1.62	41	1.75	44	0.38	9,7	1.69	43	2.25	57	0.44	11,2
1 1/4	1.75	44	2.25	57	0.38	9,7	1.81	46	2.50	64	0.44	11,2
1 1/2	1.75	44	2.50	64	0.44	11,2	1.88	48	3.00	76	0.50	12,7
2	1.88	48	3.00	76	0.50	12,7	2.00	51	3.62	92	0.62	15,7
2 1/2	2.38	60	3.62	92	0.62	15,7	2.50	64	4.25	108	0.75	19,0
3	2.56	65	4.25	108	0.75	19,0	2.69	68	5.00	127	0.88	22,4
4	2.69	68	5.50	140	0.88	22,4	2.94	75	6.25	159	1.12	28,4

## HEX HEAD PLUG

### Bouchon mâle tête hexagonale

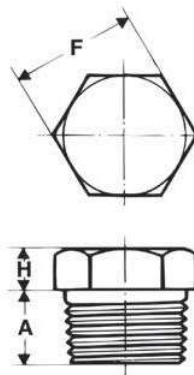

Special UNF cylindrical Plugs on request  
1" 1/4  
1" 1/8  
1" 3/8  
1" 5/8  
1" 7/8

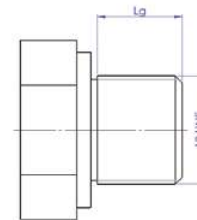

Class 3000 lbs. - 6000 lbs.  
Dimensions: ASME B 16.11  
Thread: ASME B 1.20.1

Nominal pipe size Diamètre nominal	3000-6000					
	A min		F nominal		H min.	
	inches	mm	inches	mm	inches	mm
1/4	0.44	11	0.62	15.88	0.25	6
3/8	0.50	13	0.69	17.46	0.31	8
1/2	0.56	14	0.88	22.23	0.31	8
3/4	0.62	16	1.06	26.99	0.38	10
1	0.75	19	1.38	34.93	0.38	10
1 1/4	0.81	21	1.75	44.45	0.56	14
1 1/2	0.81	21	2.00	50.80	0.62	16
2	0.88	22	2.50	63.50	0.69	18
2 1/2	1.06	27	3.00	76.20	0.75	19
3	1.12	28	3.50	88.90	0.81	21
4	1.25	32	4.62	117.48	1.00	25

## HEX HEAD BUSHING

*Réduction  
mâle-femelle*

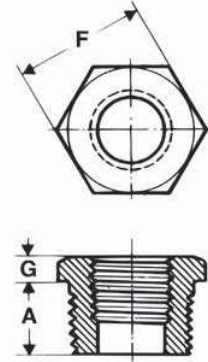

Class 3000 lbs. - 6000 lbs.  
Dimensions: ASME B 16.11  
Thread: ASME B 1.20.1

Nominal pipe size Diamètre nominal	3000-6000					
	A min		F nominal		G min.	
	inches	mm	inches	mm	inches	mm
3/8 x 1/4	0.50	13	0.69	17.46	0.16	4
1/2 x 3/8	0.56	14	0.88	22.23	0.19	5
1/2 x 1/4	0.56	14	0.88	22.23	0.19	5
3/4 x 1/2	0.62	16	1.06	26.99	0.22	6
3/4 x 1/4	0.62	16	1.06	26.99	0.22	6
1 x 3/4	0.75	19	1.38	34.93	0.25	6
1 x 1/2	0.75	19	1.38	34.93	0.25	6
1 x 1/4	0.75	19	1.38	34.93	0.25	6
1 1/4 x 1	0.81	21	1.75	44.45	0.28	7
1 1/2 x 1	0.81	21	2.00	50.80	0.31	8
1 1/2 x 3/4	0.81	21	2.00	50.80	0.31	8
1 1/2 x 1/2	0.81	21	2.00	50.80	0.31	8
2 x 1 1/2	0.88	22	2.50	63.50	0.34	9
2 x 1	0.88	22	2.50	63.50	0.34	9
2 1/2 x 2	1.06	27	3.00	76.20	0.38	10
3 x 2	1.12	28	3.50	88.90	0.41	10
4 x 3	1.25	32	4.62	117.48	0.50	13
4 x 2	1.25	32	4.62	117.48	0.50	13

## SQUARE HEAD PLUG

*Bouchon mâle  
tête carrée*

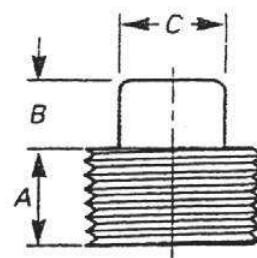

Class 3000 lbs. - 6000 lbs.  
Dimensions: ASME B 16.11  
Thread: ASME B 1.20.1

Nominal pipe size Diamètre nominal	3000-6000					
	A min		C nominal		B min.	
	inches	mm	inches	mm	inches	mm
1/8	0.38	10	0.28	7.15	0.25	6
1/4	0.44	11	0.38	9.55	0.25	6
3/8	0.50	13	0.44	11.11	0.31	8
1/2	0.56	14	0.56	14.29	0.38	10
3/4	0.62	16	0.62	15.88	0.44	11
1	0.75	19	0.81	20.64	0.50	13
1 1/4	0.81	21	0.94	23.81	0.56	14
1 1/2	0.81	21	1.12	28.58	0.62	16
2	0.88	22	1.31	33.27	0.69	18
2 1/2	1.06	27	1.50	38.10	0.75	19
3	1.12	28	1.69	42.86	0.81	21
4	1.25	32	2.50	63.50	1.00	25



## ROUND HEAD PLUG

*Bouchon mâle  
tête ronde*

Class 3000 lbs. - 6000 lbs.  
Dimensions: ASME B 16.11  
Thread: ASME B 1.20.1

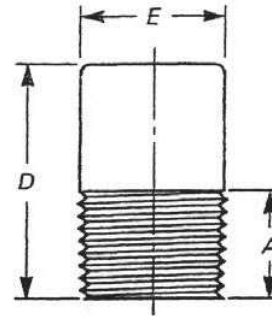

Nominal pipe size Diamètre nominal	3000-6000					
	A min		E nominal		D min	
	inches	mm	inches	mm	inches	mm
1/8	0.38	10	0.41	10	1.38	35
1/4	0.44	11	0.53	14	1.62	41
3/8	0.50	13	0.69	18	1.62	41
1/2	0.56	14	0.84	21	1.75	44
3/4	0.62	16	1.06	27	1.75	44
1	0.75	19	1.31	33	2.00	51
1 1/4	0.81	21	1.69	43	2.00	51
1 1/2	0.81	21	1.91	48	2.00	51
2	0.88	22	2.38	60	2.50	64
2 1/2	1.06	27	2.88	73	2.75	70
3	1.12	28	3.50	89	2.75	70
4	1.25	32	4.50	114	3.00	76

Special lengths available on request. *Autres longueurs disponibles sur demande.*

## FEMALE-MALE REDUCER

*Réduction femelle-mâle*

Class 3000 lbs.  
Thread: ASME B 1.20.1

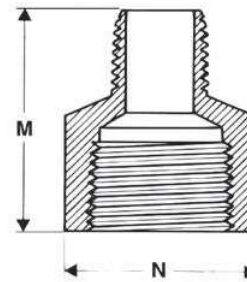

Nominal pipe size Diamètre nominal	3000			
	M <sup>(1)</sup>		N <sup>(1)</sup>	
	inches	mm	inches	mm
3/8 x 1/4	1.50	42	0.87	22
1/2 x 3/8	1.81	49	1.10	28
1/2 x 1/4	1.81	49	1.10	28
3/4 x 1/2	2.01	59	1.38	35
1 x 3/4	2.36	63	1.77	45
1 x 1/2	2.36	61	1.77	45
1 x 1/4	2.36	60	1.77	45
1 1/4 x 1	2.83	72	2.24	60
1 1/2 x 1	2.76	72	2.48	63
1 1/2 x 3/4	2.76	67	2.48	63
1 1/2 x 1/2	2.76	67	2.48	63
2 x 1/2	2.79	71	2.95	75
2 x 1	2.99	76	2.95	75
2 1/2 x 2	3.74	92	3.74	95
3 x 2	3.94	95	4.33	110
4 x 3	4.33	113	5.51	140
4 x 2	4.33	100	5.51	140

<sup>(1)</sup> Dimensions not listed in ASME B 16.11 and BS 3799 may vary according to the manufacturer.

<sup>(2)</sup> Dimensions non reprises dans ASME B 16.11 ET BS 3799, pouvant varier selon le fabricant.

## REDUCING HEXAGONAL NIPPLE *Mamelon réduit*

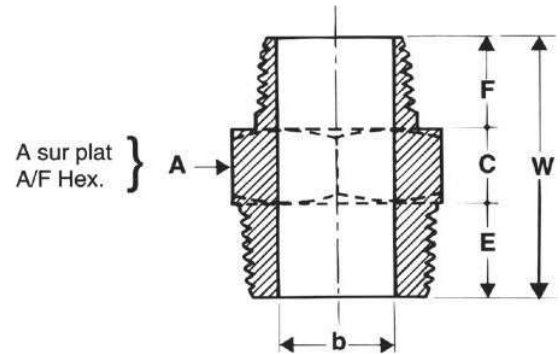

Class 3000 lbs. - 6000 lbs.  
Dimensions: BS 3799  
Thread: ASME B 1.20.1

Nominal pipe size Diamètre nominal		A (mini)		E (mini)		F (mini)		C (mini)		W (mini)		B*			
inches - pouces	mm-mm	inc.	mm	inc.	mm	inc.	mm	inc.	mm	inc.	mm	3000		6000	
												inc.	mm	inc.	mm
1/4 x 1/8	8 x 6	0.59	15	0.59	15	0.39	10	0.19	6	1.22	31	0.20	5	0.08	2
3/8 x 1/4	10 x 8	0.71	18	0.63	16	0.59	15	0.31	8	1.54	39	0.31	8	0.24	6
1/2 x 3/8	15 x 10	0.87	22	0.79	20	0.63	16	0.31	8	1.73	44	0.43	11	0.31	8
1/2 x 1/4	15 x 8	0.87	22	0.79	20	0.59	15	0.31	8	1.69	43	0.31	8	0.24	6
3/4 x 1/2	20 x 15	1.06	27	0.83	21	0.79	20	0.35	9	1.97	50	0.55	14	0.43	11
3/4 x 3/8	20 x 10	1.06	27	0.83	21	0.63	16	0.35	9	1.81	46	0.43	11	0.31	8
1 x 3/4	25 x 20	1.38	35	0.98	25	0.83	21	0.39	10	2.20	56	0.75	19	0.51	13
1 x 1/2	25 x 15	1.38	35	0.98	25	0.79	20	0.39	10	2.17	55	0.55	14	0.43	11
1 1/2 x 1	40 x 25	1.97	50	1.02	26	0.98	25	0.63	16	2.64	67	0.94	24	0.67	17
1 1/2 x 3/4	40 x 20	1.97	50	1.02	26	0.83	21	0.63	16	2.48	63	0.75	19	0.51	13
1 1/2 x 1/2	40 x 15	1.97	50	1.02	26	0.79	20	0.63	16	2.44	62	0.55	14	0.43	11
2 x 1 1/2	50 x 40	2.44	62	1.06	27	1.02	26	0.67	17	2.76	70	1.50	38	1.18	30
2 x 1	50 x 25	2.44	62	1.06	27	0.98	25	0.71	18	2.76	70	0.94	24	0.67	17
2 x 3/4	50 x 20	2.44	62	1.06	27	0.83	21	0.67	17	2.60	65	0.75	19	0.51	13
2 x 1/2	50 x 15	2.44	62	1.06	27	0.79	20	0.71	18	2.60	65	0.55	14	0.43	11

\* Dimension «b» is nominal and is subject to normal manufacturing tolerances - «b» dimension nominale soumise aux tolérances normales de fabrication

## REDUCING COUPLING *Manchon réduit*

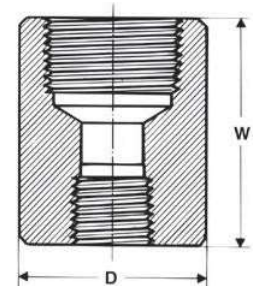

Same dimensions as for couplings  
*Dimensions identiques à celles des manchons*

Class 3000 lbs. - 6000 lbs.  
Dimensions: ASME B 16.11  
Thread: ASME B 1.20.1

Nominal pipe size Diamètre nominal	3000				6000			
	W <sup>(1)</sup>		D		W <sup>(1)</sup>		D	
	inches	mm	inches	mm	inches	mm	inches	mm
3/8 x 1/4	1.50	38	0.87	22	1.50	38	1.26	32
1/2 x 3/8	1.89	48	1.10	28	1.88	48	1.50	38
1/2 x 1/4	1.89	48	1.10	28	1.88	48	1.50	38
3/4 x 1/2	2.00	51	1.38	35	2.00	51	1.77	45
3/4 x 1/4	2.00	51	1.38	35	2.00	51	1.77	45
1 x 3/4	2.36	60	1.77	45	2.36	60	2.24	57
1 x 1/2	2.36	60	1.77	45	2.36	60	2.24	57
1 x 1/4	2.36	60	1.77	45	2.36	60	2.24	57
1 1/4 x 1	2.64	67	2.24	57	2.64	67	2.48	63
1 1/2 x 1	3.11	79	2.52	64	3.11	79	2.99	76
1 1/2 x 3/4	3.11	79	2.52	64	3.11	79	2.99	76
1 1/2 x 1/2	3.11	79	2.52	64	3.11	79	2.99	76
2 x 1 1/2	3.39	86	2.99	76	3.39	86	3.62	92
2 x 1	3.39	86	2.99	76	3.39	86	3.62	92
2 1/2 x 2	3.62	92	3.62	92	3.62	92	4.25	108
3 x 2	4.25	108	4.25	108	4.25	108	5.00	127
4 x 3	4.75	121	5.50	140	4.75	121	6.25	159
4 x 2	4.75	121	5.50	140	4.75	121	6.25	159

<sup>(1)</sup> Dimensions not listed in ASME B 16.11 and BS 3799 may vary according to the manufacturer.

<sup>(2)</sup> Dimensions non reprises dans ASME B 16.11 ET BS 3799, pouvant varier selon le fabricant.

## HEXAGONAL NIPPLE

### Mamelon

Class 3000 lbs. - 6000 lbs.

Dimensions : BS 3799

Thread: ASME B 1.20.1

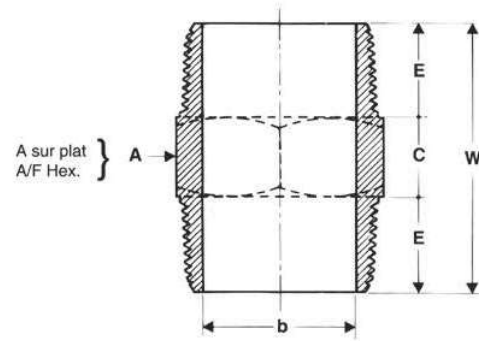

Nominal pipe size Diamètre nominal		A (mini)		E (mini)		C (mini)		W (mini)		B*			
inches - pouces	mm-mm	inc.	mm	inc.	mm	inc.	mm	inc.	mm	3000		6000	
										inc.	mm	inc.	mm
1/8	6	0.43	11	0.39	10	0.24	6	1.02	26	0.20	5	0.08	2
1/4	8	0.59	15	0.59	15	0.24	6	1.42	36	0.31	8	0.24	6
3/8	10	0.71	18	0.63	16	0.31	8	1.57	40	0.43	11	0.31	8
1/2	15	0.87	22	0.79	20	0.31	8	1.89	48	0.55	14	0.43	11
3/4	20	1.06	27	0.83	21	0.39	10	2.05	52	0.75	19	0.51	13
1	25	1.38	35	0.98	25	0.39	10	2.36	60	0.94	24	0.67	17
1 1/2	40	1.97	50	1.02	26	0.63	16	2.68	68	1.50	38	1.18	30
2	50	2.44	62	1.06	27	0.67	17	2.80	71	1.93	49	1.54	39

## WELDING BOSS

### Bossage à souder

From 1-4" to 2" O=0.375 in  
De 1-4" à 2" O=9,5 mm

Class 3000 lbs. - 6000 lbs.

Thread: ASME B 1.20.1

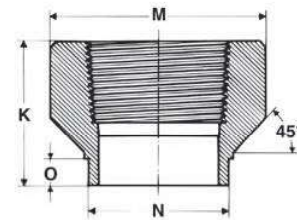
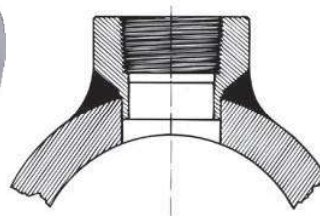

Nominal pipe size Diamètre nominal	3000 - 6000					
	K <sup>(1)</sup>		M <sup>(1)</sup>		N <sup>(1)</sup>	
	inches	mm	inches	mm	inches	mm
1/4	1.18	30,0	1.10	28	0.55	14,0
3/8	1.18	30,0	1.26	32	0.69	17,4
1/2	1.32	33,5	1.50	38	0.85	21,6
3/4	1.40	35,5	1.77	45	1.06	26,9
1	1.69	43,0	2.48	63	1.32	33,6
1 1/4	1.89	48,0	2.68	68	1.67	42,4
1 1/2	2.00	51,0	3.00	76	1.91	48,5
2	2.26	57,5	3.74	95	2.40	60,9

**90° STREET ELBOW**  
*Coude mâle-femelle*

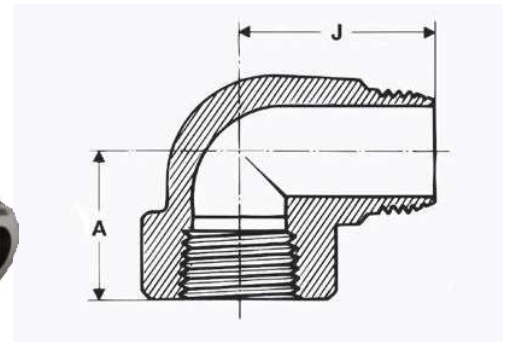

Class 3000 lbs. - 6000 lbs.  
Dimensions: ASME B 16.11  
Thread: ASME B 1.20.1

Nominal pipe size Diamètre nominal	3000				6000			
	A		J		A		J	
	inches	mm	inches	mm	inches	mm	inches	mm
1/4	0.97	25	1.25	32	1.12	28	1.50	38
3/8	1.12	28	1.50	38	1.31	33	1.62	41
1/2	1.31	33	1.62	41	1.50	38	1.88	48
3/4	1.50	38	1.88	48	1.75	44	2.25	57
1	1.75	44	2.25	57	2.00	51	2.62	66
1 1/4	2.00	51	2.62	66	2.38	60	2.81	71
1 1/2	2.38	60	2.81	71	2.50	64	3.31	84
2	2.50	64	3.31	84	3.25	83	4.13	105

**UNION ELBOW**  
**UNION TEE**  
*Coude union*  
*Té union*

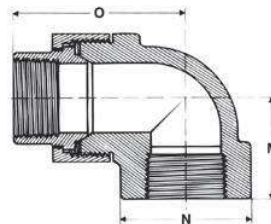

Female/  
Female  
*Femelle/  
Femelle  
(F.F.)*

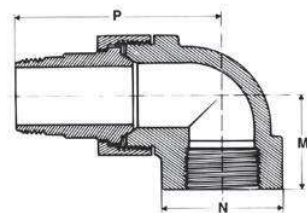
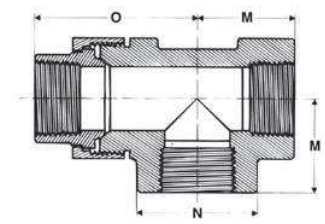

Male/  
Female  
*Mâle/  
Femelle  
(M.F.)*

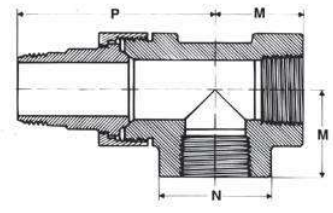

Class 3000 lbs.<sup>(1)</sup>  
Thread: ASME B 1.20.1

Nominal pipe size Diamètre nominal		1/4"	3/8"	1/2"	3/4"	1"	1" 1/4	1" 1/2	2"
<b>3000</b>									
M <sup>(1)</sup>	inches	1.14	1.16	1.40	1.56	1.79	2.40	2.40	3.31
	mm	29	29,5	35,5	39,5	45,5	61	61	84
N <sup>(1)</sup>	inches	1.30	1.30	1.50	1.81	2.20	3.00	3.00	4.02
	mm	33	33	38	46	56	76	76	102
O <sup>(1)</sup>	inches	2.03	2.07	2.42	2.64	2.99	3.70	3.94	5.12
	mm	51,5	52,5	61,5	67	76	94	100	130
P <sup>(1)</sup>	inches	2.64	2.85	3.27	3.55	4.25	4.84	5.08	6.30
	mm	67	72,5	83	90	102	123	129	160

<sup>(1)</sup> Dimensions not listed in ASME B 16.11 and BS 3799 may vary according to the manufacturer.

<sup>(2)</sup> Dimensions non reprises dans ASME B 16.11 ET BS 3799, pouvant varier selon le fabricant.

## FEMALE-FEMALE UNION

Union  
femelle-femelle

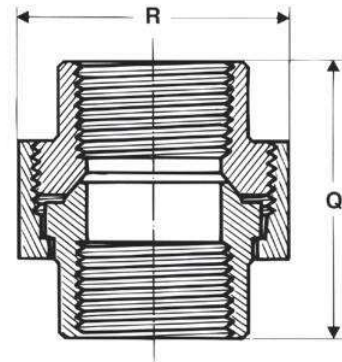

Class 3000 lbs. - 6000 lbs.  
Dimensions: MSS SP 83-BS 3799  
Thread: ASME B 1.20.1

Nominal pipe size Diamètre nominal	3000				6000			
	Q <sup>(1)</sup>		R <sup>(1)</sup>		Q <sup>(1)</sup>		R <sup>(1)</sup>	
	inches	mm	inches	mm	inches	mm	inches	mm
1/4	1.67	45	1.42	36				
3/8	1.87	51	1.62	41				
1/2	2.05	52	1.81	46	2.72	63	2.36	64,5
3/4	2.25	57	2.20	56	2.84	63	2.84	64,5
1	2.48	63	2.56	65	3.15	71	3.15	80,0
1 1/4	2.76	66	3.07	80	3.50	89	3.70	87,0
1 1/2	30.7	78	3.39	87	4.25	89	3.94	100,0
2	3.50	91	4.06	100	4.49	119	4.80	122,0
2 1/2	4.49	118	4.80	125	5.13	128	5.67	144,0
3	5.12	120	5.67	144	5.91	148	7.09	200,0
4	5.91	148	7.09	200				

<sup>(1)</sup> Dimensions may vary according to the manufacturer. *Dimensions pouvant varier selon le fabricant.*

## MALE-FEMALE UNION

Union  
mâle-femelle

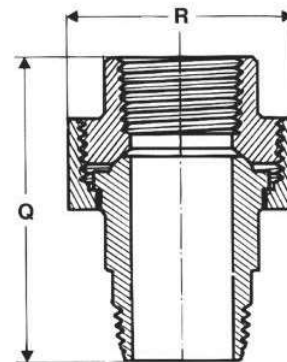

Class 3000 lbs. - 6000 lbs.  
Thread: ASME B 1.20.1

Nominal pipe size Diamètre nominal	3000				6000			
	Q <sup>(1)</sup>		R <sup>(1)</sup>		Q <sup>(1)</sup>		R <sup>(1)</sup>	
	inches	mm	inches	mm	inches	mm	inches	mm
1/4	2.48	61	1.26	36				
3/8	2.72	69	1.50	41				
1/2	3.03	75	1.81	46	3.72	94,5	2.36	64,5
3/4	3.15	80	2.00	56	3.88	98,5	2.84	64,5
1	3.82	90	2.36	65	4.25	108,0	3.15	80,0
1 1/4	3.98	98	2.84	80	4.72	120,0	3.70	87,0
1 1/2	4.33	100	3.15	87	5.44	138,0	3.94	100,0
2	4.72	120	3.70	100	5.75	146,0	4.80	122,0

<sup>(1)</sup> Dimensions may vary according to the manufacturer. *Dimensions pouvant varier selon le fabricant.*



## SWAGE NIPPLE

### Swedge nipple

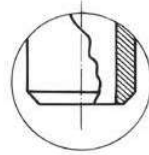

Buttwelding end according to ANSI B 16-25  
Extrémité à souder suivant ANSI B 16-25

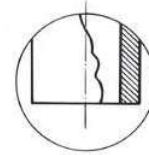

Cut square plain end  
Extrémité lisse coupée d'équerre

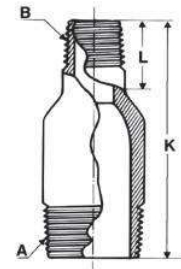

Thread ends according to ANSI B 1.20.1  
Extrémités filetées suivant ANSI B 1.20.1

Class 3000 lbs. - 6000 lbs.  
Dimensions: BS 3799 / MSS SP95

Nominal pipe sizes Diamètres nominaux A x B	3000						Thickness according to ANSI B 36-10 Épaisseur suivant ANSI B36-10		
	K				L				
	BS3799		MSS SP95						
	inches	mm	inches	mm					
3/8 x 1/4	3.74	76	2.52	64	0.63	16	Sch 40	Sch 80	
1/2 x 3/8	3.50	89	2.76	70	0.75	19	Sch 40	Sch 80	
1/2 x 1/4	3.50	89	2.76	70	0.75	19	Sch 40	Sch 80	
3/4 x 1/2	3.75	95	2.99	76	0.87	22	Sch 40	Sch 80	Sch 160
3/4 x 1/4	3.75	95	2.99	76	0.87	22	Sch 40	Sch 80	
1 x 3/4	4.02	102	3.50	89	0.87	22	Sch 40	Sch 80	Sch 160
1 x 1/2	4.02	102	3.50	89	0.87	22	Sch 40	Sch 80	Sch 160
1 x 1/4	4.02	102	3.50	89	0.87	22	Sch 40	Sch 80	Sch 160
1 1/4 x 1	4.49	114	4.02	102	0.98	25	Sch 40	Sch 80	Sch 160
1 1/2 x 1	4.49	114	4.49	114	0.98	25	Sch 40	Sch 80	Sch 160
1 1/2 x 3/4	4.49	114	4.49	114	0.98	25	Sch 40	Sch 80	Sch 160
1 1/2 x 1/2	6.50	165	6.50	165	0.98	25	Sch 40	Sch 80	Sch 160
2 x 1 1/2	6.50	165	6.50	165	1.14	29	Sch 40	Sch 80	Sch 160
2 x 1	6.50	165	6.50	165	1.14	30	Sch 40	Sch 80	Sch 160
2 1/2 x 2	7.01	178	7.01	178	1.26	32	Sch 40	Sch 80	Sch 160
3 x 2	7.99	203	7.99	203	1.61	41	Sch 40	Sch 80	Sch 160
4 x 3	9.02	229	9.02	229	1.89	48	Sch 40	Sch 80	Sch 160
4 x 2	9.02	229	9.02	229	1.89	48	Sch 40	Sch 80	Sch 160

Variations in outside diameter and thickness according to ASTM A 106. Tolérances sur diamètre et épaisseur suivant ASTM A 106.

## CODE USED IN MATERIAL LIST OF SWAGE NIPPLES

### Code utilisé pour la nomenclature des swedge nipples

#### Reduced nipple

Mamelon tube réduit

- P.B.E. Plain both ends - Deux extrémités d'équerre et lisse
- P.L.E. Plain large end - Grande extrémité d'équerre et lisse
- P.S.E. Plain small end - Petite extrémité d'équerre et lisse
- B.B.E. Bevelled both ends - Deux extrémités chanfreinées
- B.L.E. Bevelled large end - Grande extrémité chanfreinée
- B.S.E. Bevelled small end - Petite extrémité chanfreinée
- T.B.E. Threaded both ends - Deux extrémités filetées
- T.L.E. Threaded large end - Grande extrémité filetée
- T.S.E. Threaded small end - Petite extrémité filetée
- B.O.E. Bevelled one end - Une extrémité chanfreinée
- P.O.E. Plain one end - Une extrémité d'équerre et lisse
- T.O.E. Threaded one end - Une extrémité filetée

#### For barrel nipples only.

S'appliquent uniquement aux mamelons tubes.

#### Two codes may be used on the same item for example :

On peut trouver pour une même pièce deux codes réunis.  
Exemple :

#### 1 Swage Nipple 3 x 2 BLE-TSE

Which means : Ce qui se lit :

- Bevelled large end - Large extrémité chanfreinée
- Threaded small end - Petite extrémité filetée

## BOSS Bossage

Class 3000 lbs. - 6000 lbs.  
Dimensions : ASME B 16.11  
Thread: ASME B 1.20.1

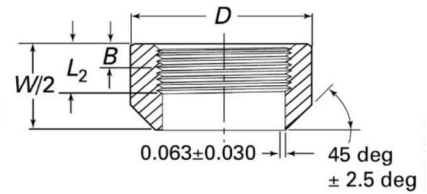

Nominal pipe size Diamètre nominal	3000-6000		3000		6000	
	W		D		D	
	inches	mm	inches	mm	inches	mm
1/4	1.38	35	0.75	19	1.00	25
3/8	1.50	48	0.88	22	1.25	32
1/2	1.88	48	1.12	28	1.50	38
3/4	2.00	51	1.38	35	1.75	44
1	2.38	60	1.75	44	2.25	57
1 1/4	2.62	67	2.25	57	2.50	64
1 1/2	3.12	79	2.50	64	3.00	76
2	3.38	86	3.00	76	3.62	92
2 1/2	3.62	92	3.62	92	4.25	108
3	4.25	108	4.25	108	5.00	127
4	4.75	121	5.50	140	6.25	159

We can produce Boss as per End-user specific Design

## COUPLET Couplet

Class 3000 lbs. - 6000 lbs.  
Dimensions : ASME B 16.11  
Thread: ASME B 1.20.1

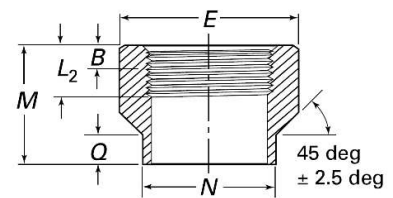

Nominal pipe size Diamètre nominal	3000		6000		3000-6000			
	E		E		M		N	
	inches	mm	inches	mm	inches	mm	inches	mm
1/4	0.928	23,8	1.000	25,4	1.188	30,2	0.688	17,5
3/8	1.063	27,0	1.250	31,8	1.188	30,2	0.813	20,7
1/2	1.313	33,4	1.500	38,1	1.313	33,4	0.938	23,8
3/4	1.500	38,1	1.750	44,5	1.375	34,9	1.063	27,0
1	1.813	46,1	2.250	57,2	1.688	42,9	1.313	33,4
1 1/4	2.188	55,6	2.500	63,5	1.875	47,6	1.688	42,9
1 1/2	2.500	63,5	3.000	76,2	2.000	50,8	1.938	49,2
2	3.125	79,4	3.625	79,4	2.250	57,2	2.438	61,9
2 1/2	3.625	92,1	4.250	92,1	2.500	63,5	2.875	73,0
3	4.375	111,1	5.000	111,1	2.750	69,9	3.500	114,3
4	5.563	141,3	6.250	141,3	3.000	76,2	4.500	114,3



## ELBOW

### Coude

For dimensions B-C-D-G-J refer to dimensions of S.W. fittings  
*Dimensions B-C-D-G-J, voir caractéristiques dimensionnelles*

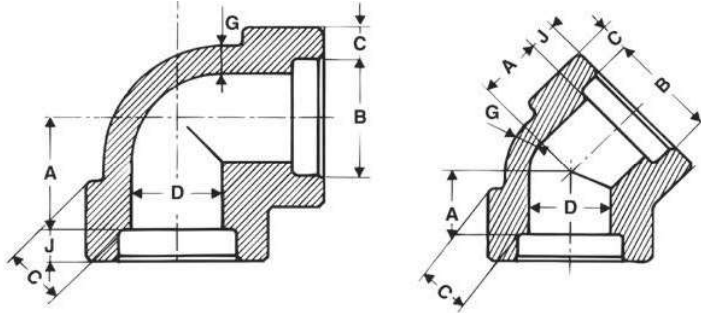

Class 3000 lbs. - 6000 lbs.  
Socket welding end and dimensions according to ASME: B16.11

## TEE

### Té Croix

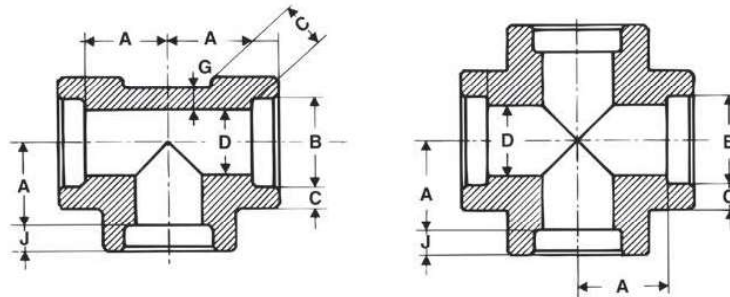

Class 3000 lbs. - 6000 lbs.  
Socket welding end and dimensions according to ASME: B16.11

Nominal pipe size Diamètre nominal	Center to bottom of socket A - Centre au fond de l'emboîtement A									
	Coude 90° - Té - Croix				Coude 45°				Tolérances ±	
	3000		6000		3000		6000			
	inches	mm	inches	mm	inches	mm	inches	mm	inches	mm
1/4	0.44	11,0	0.53	13,5	0.31	8,0	0.31	8,0	0.03	1,0
3/8	0.53	13,5	0.62	15,5	0.31	8,0	0.44	11,0	0.06	1,5
1/2	0.62	15,5	0.75	19,0	0.44	11,0	0.50	12,5	0.06	1,5
3/4	0.75	19,0	0.88	22,5	0.50	13,0	0.56	14,0	0.06	1,5
1	0.88	22,5	1.06	27,0	0.56	14,0	0.69	17,5	0.08	2,0
1 1/4	1.06	27,0	1.25	32,0	0.69	17,5	0.81	20,5	0.08	2,0
1 1/2	1.25	32,0	1.50	38,0	0.81	20,5	1.00	25,5	0.08	2,0
2	1.50	38,0	1.62	41,0	1.00	25,5	1.12	28,5	0.08	2,0
2 1/2	1.62	41,0			1.12	28,5			0.10	2,5
3	2.25	57,0			1.25	32,0			0.10	2,5
4	2.62	66,5			1.62	41,0			0.10	2,5

5" and 6" Available on request (Forgings available from stock) Manufacturer standard  
Red. Tees & Red. Crosses – refer to page 69

**COUPLING**  
**HALF-COUPLING**  
*Manchon*  
*Demi-manchon*



For dimensions B-C-D-J refer to dimensions of S.W. fittings  
*Dimensions B-C-D-J, voir caractéristiques dimensionnelles*

Class 3000 lbs. - 6000 lbs.  
Socket welding end and dimensions according to ASME: B16.11

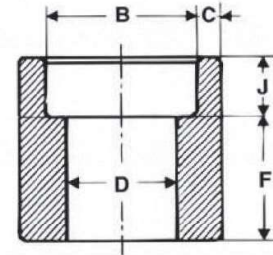
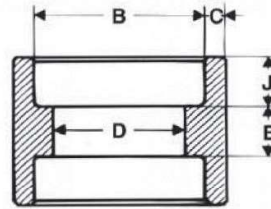

Nominal pipe size Diamètre nominal	Laying lengths - Côtes de montage							
	Couplings - Manchons - E				Half-couplings - Demi-manchons - F			
	3000 - 6000		Tolérances ±		3000 - 6000		Tolérances ±	
	inches	mm	inches	mm	inches	mm	inches	mm
1/4	0.25	6,5	0.06	1,5	0.62	16,0	0.06	1,5
3/8	0.25	6,5	0.12	3,0	0.69	17,5	0.12	3,0
1/2	0.38	9,5	0.12	3,0	0.88	22,5	0.12	3,0
3/4	0.38	9,5	0.12	3,0	0.94	24,0	0.12	3,0
1	0.50	12,5	0.16	4,0	1.12	28,5	0.16	4,0
1 1/4	0.50	12,5	0.16	4,0	1.19	30,0	0.16	4,0
1 1/2	0.50	12,5	0.16	4,0	1.25	32,0	0.16	4,0
2	0.75	19,0	0.16	4,0	1.62	41,0	0.16	4,0
2 1/2	0.75	19,0	0.20	5,0	1.69	43,0	0.20	5,0
3	0.75	19,0	0.20	5,0	1.75	44,5	0.20	5,0
4	0.75	19,0	0.20	5,0	1.88	48,0	0.20	5,0

5" and 6" Available on request (Forgings available from stock) Manufacturer standard

**CAP**  
*Bouchon femelle*

For dimensions B-J refer to dimensions of S.W. fittings  
*Dimensions B-J, voir caractéristiques dimensionnelles*

Class 3000 lbs. - 6000 lbs.  
Socket welding end and dimensions according to ASME: B16.11

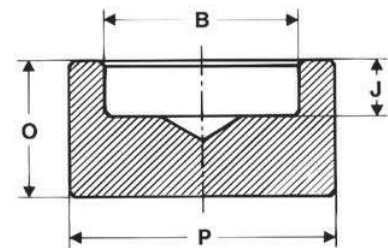

Nominal pipe size Diamètre nominal	3000				6000			
	O <sup>(1)</sup>		p <sup>(1)</sup>		O <sup>(1)</sup>		p <sup>(1)</sup>	
	inches	mm	inches	mm	inches	mm	inches	mm
1/4	0.79	20	0.87	22	0.79	20	0.90	26
3/8	0.79	20	1.02	26	0.79	20	1.10	28
1/2	0.79	20	1.26	32	0.87	22	1.38	35
3/4	0.94	24	1.50	38	0.98	25	1.57	45
1	1.06	27	1.77	45	1.10	28	1.97	50
1 1/4	1.06	27	2.17	55	1.10	28	2.36	60
1 1/2	1.10	28	2.48	63	1.18	30	2.64	67
2	1.30	33	2.95	75	1.42	36	3.35	85
2 1/2	1.42	36	3.62	95	1.53	39	3.94	100
3	1.57	40	4.33	110	1.73	44	4.72	120
4	1.77	45	5.51	140	2.01	51	5.91	150

<sup>(1)</sup> Dimensions not listed in ASME B 16.11 and BS 3799 may vary according to the manufacturer.

<sup>(2)</sup> Dimensions non reprises dans ASME B 16.11 ET BS 3799, pouvant varier selon le fabricant.

## REDUCING COUPLING

### Manchon réduit

For dimensions B-D-J refer to dimensions of S.W. fittings

*Dimensions B-D-J, voir caractéristiques dimensionnelles*

Class 3000 lbs. - 6000 lbs.

Socket welding end and dimensions according to ASME: B16.11

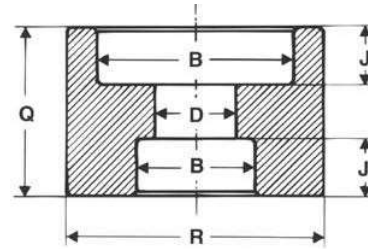

Nominal pipe size Diamètre nominal	3000				6000			
	Q <sup>(1)</sup>		R <sup>(1)</sup>		Q <sup>(1)</sup>		R <sup>(1)</sup>	
	inches	mm	inches	mm	inches	mm	inches	mm
3/8 x 1/4	0.98	25,0	1.02	26,0	0.98	25,0	1.10	28,0
1/2 x 3/8	1.10	28,0	1.26	32,0	1.10	28,0	1.38	35,0
1/2 x 1/4	1.10	28,0	1.26	32,0	1.10	28,0	1.38	35,0
3/4 x 1/2	1.22	31,0	1.50	38,0	1.22	31,0	1.77	45,0
3/4 x 1/4	1.22	31,0	1.50	38,0	1.22	31,0	1.77	45,0
1 x 3/4	1.46	37,0	1.77	45,0	1.46	37,0	1.97	50,0
1 x 1/2	1.34	34,0	1.77	45,0	1.34	34,0	1.97	50,0
1 x 1/4	1.34	34,0	1.77	45,0	1.34	34,0	1.97	50,0
1 1/4 x 1	1.46	37,0	2.17	55,0	1.46	37,0	2.36	60,0
1 1/2 x 1	1.46	37,0	2.48	63,0	1.50	38,0	2.64	67,0
1 1/2 x 3/4	1.46	37,0	2.48	63,0	1.50	38,0	2.64	67,0
1 1/2 x 1/2	1.34	34,0	2.48	63,0	1.50	38,0	2.64	67,0
2 x 1 1/2	1.81	46,0	2.95	75,0	2.01	51,0	3.35	85,0
2 x 1	1.81	46,0	2.95	75,0	2.01	51,0	3.35	85,0

## WELDING BOSS

### Bossage à souder

For dimensions B-D-J refer to dimensions of S.W. fittings

*Dimensions B-D-J, voir caractéristiques dimensionnelles*

From 1-4" to 2" L=0.375 in  
De 1-4" à 2" L=9,5mm

Class 3000 lbs. - 6000 lbs.

Socket welding end and dimensions according to ASME: B16.11

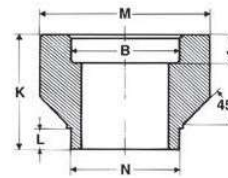
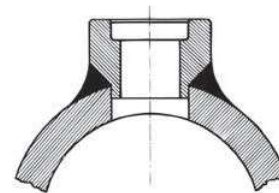

	3000 - 6000					
	K <sup>(1)</sup>		M <sup>(1)</sup>		N <sup>(1)</sup>	
	inches	mm	inches	mm	inches	mm
1/4	1.18	30,0	1.10	28,0	0.55	14,0
3/8	1.18	30,0	1.10	28,0	0.69	17,4
1/2	1.32	33,5	1.50	38,0	0.85	21,6
3/4	1.38	35,5	1.77	45,0	1.06	26,9
1	1.69	43,0	1.97	50,0	1.32	33,6
1 1/4	1.89	48,0	2.48	63,0	1.67	42,4
1 1/2	1.97	50,0	2.68	68,0	1.91	48,5
2	2.26	57,5	3.74	95,0	2.40	60,9

<sup>(1)</sup> Dimensions not listed in ASME B 16.11 and BS 3799 may vary according to the manufacturer.

<sup>(2)</sup> Dimensions non reprises dans ASME B 16.11 ET BS 3799, pouvant varier selon le fabricant

## BOSS Bossage

For dimensions B-C-D-J refer to dimensions of S.W. fittings  
*Dimensions B-C-D-J, voir caractéristiques dimensionnelles*

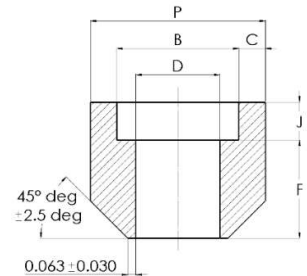

Class 3000 lbs. - 6000 lbs.  
Socket welding end and dimensions  
According to ASME: B16.11

Nominal pipe size Diamètre nominal	3000		6000		3000-6000			
	P		P		F		Tolérances ±	
	inches	mm	inches	mm	inches	mm	inches	mm
1/2	0.91	32	1.38	35	0.88	22,5	0.06	3,0
3/4	1.50	38	1.77	45	0.94	24,0	0.06	3,0
1	1.77	45	1.97	50	1.12	28,5	0.08	4,0
1 1/4	2.17	55	2.36	60	1.19	30,0	0.08	4,0
1 1/2	2.48	63	2.68	68	1.25	32,0	0.08	4,0
2	2.95	75	3.35	85	1.62	41,0	0.08	4,0

We can produce Boss as per End-user specific Design

## COUPLET Couplet

For dimensions B-C-D-J-Q refer to dimensions of S.W. fittings  
*Dimensions B-C-D-J-Q, voir caractéristiques dimensionnelles*

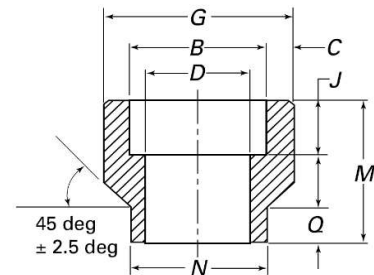

Class 3000 lbs. - 6000 lbs.  
Socket welding end and dimensions  
According to ASME: B16.11

Nominal pipe size Diamètre nominal	3000		6000		3000-6000			
	G		G		M		N	
	inches	mm	inches	mm	inches	mm	inches	mm
1/4	0.94	23,8	1.00	25,4	1.19	30,2	0.688	17,5
3/8	1.06	27,0	1.25	31,8	1.19	30,2	0.813	20,7
1/2	1.31	33,4	1.50	38,1	1.31	33,4	0.938	23,8
3/4	1.50	38,1	1.75	44,5	1.38	34,9	1.063	27,0
1	1.81	46,1	2.25	57,2	1.88	47,6	1.688	42,9
1 1/4	2.19	55,6	2.50	63,5	1.88	47,6	1.688	42,9
1 1/2	2.50	63,5	3.00	76,2	2.00	50,8	1.938	49,2
2	3.13	79,4	3.63	92,1	2.25	57,2	2.438	61,9
2 1/2	3.63	92,1	4.25	108,0	2.50	63,5	2.875	73,0
3	4.38	111,1	5.00	127,0	2.75	69,9	3.500	88,9
4	5.56	141,3	6.25	158,8	3.00	76,2	4.500	114,3

<sup>(1)</sup> Dimensions not listed in ASME B 16.11 and BS 3799 may vary according to the manufacturer.

<sup>(1)</sup> Dimensions non reprises dans ASME B 16.11 ET BS 3799, pouvant varier selon le fabricant.

## REDUCING INSERT

### Réduction mâle-femelle

Application of reducing insert  
Exemple d'utilisation  
d'une réduction  
mâle-femelle

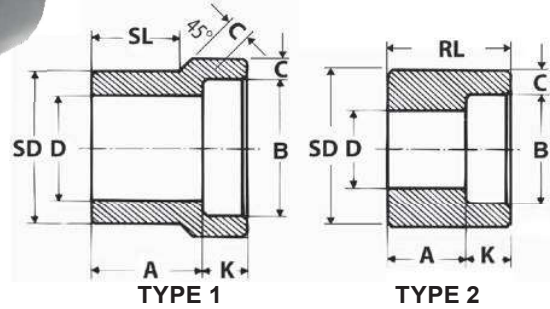

Class 3000 lbs. - 6000 lbs.  
Dimensions: MSS SP79

Nominal pipe size Diamètre nominal	Type(2)		Socket		Shank Dia. SD	Laying length A		Bore D		Wall min. C		Length			
	3M	6M	Dia. B	Depth Min. K		3M	6M	3M	6M	3M	6M	SL		RL (min)	
												3M	6M	3M	6M
3/8" x 1/4"	1	1	14,4	9,5	17,1	19,0	21,3	9,2	6,3	3,78	4,60	14,2	15,7		
1/2" x 3/8"	1	1	17,8	9,5	21,3	20,6	23,1	12,5	9,1	4,01	5,03	15,7	15,7		
1/2" x 1/4"	1	1	14,4	9,5	21,3	20,6	20,6	9,2	6,3	3,78	4,60	15,7	15,7		
3/4" x 1/2"	1	1	22,0	9,5	26,7	22,4	25,4	15,8	11,7	4,67	5,97	17,5	19,0		
3/4" x 3/8"	2	1	17,8	9,5	26,7	15,7	22,4	12,5	9,1	4,01	5,03		19,0	26,9	
3/4" x 1/4"	2	2	14,4	9,5	26,7	17,5	22,4	9,2	6,3	3,78	4,60			26,9	32,0
1" x 3/4"	1	1	27,4	12,5	33,4	23,9	28,4	20,9	15,5	4,90	6,96	19,0	20,6		
1" x 1/2"	2	1	22,0	9,5	33,4	15,7	28,4	15,8	11,7	4,67	5,97		20,6	28,4	
1" x 3/8"	2	2	17,8	9,5	33,4	17,5	22,4	12,5	9,1	4,01	5,03			28,4	33,2
1" x 1/4"	2	2	14,4	9,5	33,4	19,0	23,9	9,2	6,3	3,78	4,60			28,4	33,2
1"1/4 x 1"	1	1	34,1	12,5	42,2	25,4	30,2	26,6	20,7	5,69	7,92	20,6	22,4		
1"1/4 x 3/4"	2	2	27,4	12,5	42,2	17,5	20,6	20,9	15,5	4,90	6,96			31,7	34,7
1"1/4 x 1/2"	2	2	22,0	9,5	42,2	19,0	22,4	15,8	11,7	4,67	5,97			31,7	34,7
1"1/4 x 3/8"	2	2	17,8	9,5	42,2	20,6	23,9	12,5	9,1	4,01	5,03			31,7	34,7
1"1/4 x 1/4"	2	2	14,4	9,5	42,2	22,4	25,4	9,2	6,3	3,78	4,60			31,7	34,7
1"1/2 x 1"1/4"	1	1	42,9	12,5	48,2	28,4	35,0	35,0	29,4	6,07	7,92	22,4	25,4		
1"1/2 x 1"	2	1	34,1	12,5	48,2	17,5	29,2	26,6	20,7	5,69	7,92		25,4	33,2	
1"1/2 x 3/4"	2	2	27,4	12,5	48,2	19,0	25,4	20,9	15,5	4,90	6,96			33,2	39,6
1"1/2 x 1/2"	2	2	22,0	9,5	48,2	20,6	26,9	15,8	11,7	4,67	5,97			33,2	39,6
1"1/2 x 3/8"	2	2	17,8	9,5	48,2	22,4	28,4	12,5	9,1	4,01	5,03			33,2	39,6
2" x 1"1/2"	1	1	49,0	12,5	60,3	31,8	38,9	40,8	33,9	6,35	8,92	25,4	28,7		
2" x 1"1/4"	2	2	42,9	12,5	60,3	20,6	23,9	35,0	29,4	6,07	7,92			38,1	41,1
2" x 1"	2	2	34,1	12,5	60,3	22,4	25,4	26,6	20,7	5,69	7,92			38,1	41,1
2" x 3/4"	2	2	27,4	12,5	60,3	23,9	26,9	20,9	15,5	4,90	6,96			38,1	41,1
2" x 1/2"	2	2	22,0	9,5	60,3	25,4	28,4	15,8	11,7	4,67	5,97			38,1	41,1
2"1/2 x 2"	1	1	61,4	16	73,0	46,0	42,7	52,4	42,8	6,93	10,92	38,1	31,8		
2"1/2 x 1"1/2"	2	2	49,0	12,5	73,0	35,0	35,0	40,8	33,9	6,35	8,92			53,8	53,8
2"1/2 x 1"1/4"	2	2	42,9	12,5	73,0	36,6	36,6	35,0	29,4	6,07	7,92			53,8	53,8
2"1/2 x 1"	2	2	34,1	12,5	73,0	38,1	38,1	26,6	20,7	5,69	7,92			53,8	53,8
2"1/2 x 3/4"	2	2	27,4	12,5	73,0	39,6	38,1	20,9	15,5	4,90	6,96			53,8	53,8
3" x 2"1/2"	1	1	74,1	16	88,9	38,1	57,2	62,7	54,0	8,76	11,91	31,8	44,4		
3" x 2"	2	2	61,4	16	88,9	25,4	31,8	52,4	42,8	6,93	10,92			47,4	53,8
3" x 1"1/2"	2	2	49,0	12,5	88,9	28,4	31,8	40,8	33,9	6,35	8,92			47,4	53,8
3" x 1"1/4"	2	2	42,9	12,5	88,9	30,2	31,8	35,0	29,4	6,07	7,92			47,4	53,8
3" x 1"	2	2	34,1	12,5	88,9	31,8	31,8	26,6	20,7	5,69	7,92			47,4	53,8
4" x 3"	2	X	90,0	16	114,3	33,3	X	77,9	X	9,52	X			60,4	X
4" x 2"1/2"	2	X	74,1	16	114,3	38,1	X	62,7	X	8,76	X			60,4	X
4" x 2"	2	X	61,4	16	114,3	38,1	X	52,4	X	6,93	X			60,4	X
4" x 1"1/2"	2	X	49,0	12,5	114,3	41,1	X	40,8	X	6,35	X			60,4	X
4" x 1"1/4"	2	X	42,9	12,5	114,3	42,9	X	35,0	X	6,07	X			60,4	X

(1) At the option of the manufacturer Type 2 Reducers may be furnished in Type 1 configuration. (2) 3M and 6M symbols denote 3000 and 6000 classes  
(1) Option du fabricant - inserts type 2 peuvent être livrés en configuration type 1. (2) 3M et 6M valent pour les classes 3000 et 6000

## UNION

### Union

For dimensions B-C-D-J refer to dimensions of S.W. fittings

*Dimensions B-C-D-J, voir caractéristiques dimensionnelles*

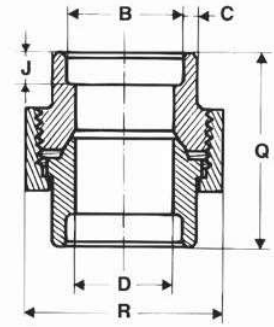

Class 3000 lbs. - 6000 lbs.

Dimensions: MSS SP 83-BS 3799

Diamètre nominal Nominal pipe size	3000				6000			
	Q <sup>(1)</sup>		R <sup>(1)</sup>		Q <sup>(1)</sup>		R <sup>(1)</sup>	
	inches	mm	inches	mm	inches	mm	inches	mm
1/4	1.67	42,5	1.42	36,0				
3/8	2.00	51,0	1.62	41,0				
1/2	2.25	57,0	1.81	46,0	2.25	57,0	2.20	56,0
3/4	2.25	57,0	2.20	56,0	2.48	63,0	2.54	64,5
1	2.48	63,0	2.54	64,5	2.80	71,0	3.15	80,0
1 1/4	2.76	68,0	3.07	80,0	2.99	76,0	3.43	87,0
1 1/2	3.03	77,0	3.43	87,0	3.50	89,0	3.94	100,0
2	3.62	92,0	3.94	100,0	4.65	118,0	4.80	125,0
2 1/2	4.65	118,0	4.80	125,0				
3	4.65	118,0	5.67	144,0				
4	5.91	148,0	7.09	200,0				

<sup>(1)</sup> Dimensions may vary according to the manufacturer. *Dimensions pouvant varier selon le fabricant.*

## BULL PLUG

BW / PE end per B16.25 / B16.11

Rating: 3000 / 6000 / 9000

BW Sch: STD / XS / 80 / 160 & XXS

Dimensions: MSS SP 95

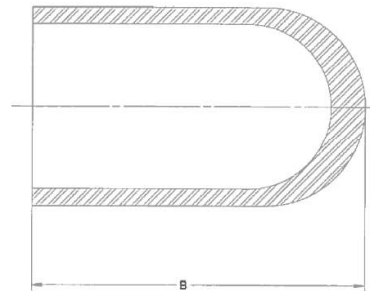

Diamètre nominal Nominal pipe size	Outside Diameter		End-to-End "B"		Diamètre nominal Nominal pipe size	Outside Diameter		End-to-End "B"	
	inches	mm	inches	mm		inches	mm	inches	mm
1/8	0.405	10,3	2.00	51	2 1/2	2.87	73,0	5.00	127
1/4	0.540	13,7	2.00	51	3	3.50	88,9	6.00	152
3/8	0.675	17,1	2.25	57	3 1/2	4.00	101,6	6.50	165
1/2	0.840	21,3	2.50	64	4	4.50	114,3	7.00	178
3/4	1.050	26,7	2.75	70	5	5.56	141,3	8.50	216
1	1.315	33,4	3.00	76	6	6.62	168,3	10.00	254
1 1/4	1.660	42,2	3.25	83	8	8.62	219,1	11.00	279
1 1/2	1.900	48,3	3.50	89	10	10.7	273,0	13.00	330
2	2.375	60,3	4.00	102	12	12.7	323,8	14.00	356

## I. HIGH PRESSURE DIVISION DIVISION HAUTE PRESSION

2. Branch outlets (carbon, alloy, stainless steels, duplex, super duplex and nickel alloy)  
*Raccord de dérivation renforcés  
(acier carbone, alliés, inoxydables)*



<b>REINFORCED BRANCH FITTINGS - RACCORDS DE DÉRIVATION RENFORCÉS</b> .....	<b>25</b>
<b>WELD-OUTLET STANDARD (STD)</b> .....	<b>26</b>
<b>LIGHT WEIGHT-OUTLET</b> .....	<b>26</b>
<b>WELD-OUTLET EXTRA STRONG (XS)</b> .....	<b>27</b>
<b>WELD-OUTLET SH 160 / XXS</b> .....	<b>27</b>
<b>SOCKET WELDING FITTINGS - RACCORDS EMBOÎTÉS SOUDÉS</b> .....	<b>28</b>
<b>THREADED FITTINGS - RACCORDS TARAUDÉS</b> .....	<b>28</b>
<b>SOCK-OUTLET</b> .....	<b>29</b>
<b>THREADED OUTLET - RACCORD TARAUDÉ</b> .....	<b>30</b>
<b>JD-OUTLET</b> - .....	<b>31</b>
<b>NIP OUTLET - RACCORD ALLONGÉ</b> .....	<b>35</b>
<b>ELB-OUTLET - ELBOW OUTLET</b> .....	<b>36</b>
<b>LATERAL OUTLET - LATERAL OUTLET</b> .....	<b>37</b>
<b>SWEEP-OUTLET</b> .....	<b>38</b>
<b>INSERT WELD-OUTLET</b> .....	<b>38</b>
<b>INSERT LATERAL OUTLET</b> .....	<b>39</b>
<b>INSERT FLANGED OUTLET</b> .....	<b>39</b>
<b>FLANGED NIPPLE OUTLET</b> .....	<b>40</b>
<b>LATRO FLANGED OUTLET</b> .....	<b>41</b>
<b>ELBO FLANGED OUTLET</b> .....	<b>41</b>
<b>SWEPEO FLANGED OUTLET</b> .....	<b>41</b>





## REINFORCED BRANCH FITTINGS

### Raccords de dérivation renforcés

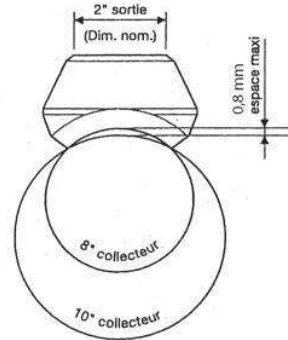
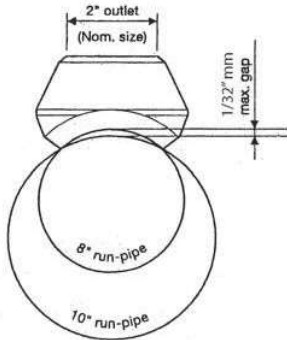

#### General

Material manufactured by forging

Materials frequently used:

- ASTM A 105 - A 350 - A 182 - A 694. These fittings are not standardised and are manufactured in accordance with the recommendations of the ASME B 31.3. code

#### Description

This type of fittings is installed either straight or at an angle to the main pipe. As the bearing surface fits the shape of the pipe exactly, the outside diameter of the pipe must be known. Range: NPS 3-8" to 60". The main pipe and the fittings are connected by means of a fillet weld.

The fitting and the branch pipe can be connected in several different ways

Outlet radius of branch fittings have been unified in order to allow, generally speaking up to size 4", the use of same fitting on different run pipe sizes, with a maximum gap of 1-32" (0,8 mm) between the top of the run pipe and the base of the fitting. For outlet sizes over 4", usually a specific radius is required for each run size. Each fitting is marked with its nominal size (outlet diameter) and the range of run sizes on which it can be welded.

#### Généralités

Matériel obtenu par forgeage

Matériaux couramment utilisés :

- ASTM A 105 - A 350 - A 182 - A 694. Ces raccords, n'étant pas normalisés, sont conçus suivant les recommandations du code ASME B 31.3.

#### Descriptif

Ce type de raccord est posé droit ou incliné sur le collecteur principal ; la face d'appui du raccord épouse la forme de ce collecteur, d'où la nécessité de connaître le diamètre extérieur de celui-ci. Possibilité NPS 3-8" à 60". La liaison collecteur-raccord se fait par une soudure d'angle. La liaison raccord-tube de dérivation peut se faire de plusieurs manières.

Les rayons de raccordement des raccords de dérivation ont été unifiés pour permettre l'utilisation, en général jusqu'au diamètre de sortie 4", d'un même raccord sur différents collecteurs, avec un espace maximum de 0,8 mm (1-32") entre le sommet du collecteur et la base du raccord. Pour les diamètres de sortie supérieurs à 4", le rayon de raccordement est en général spécifique à chaque diamètre de collecteur. Chaque raccord est Marqué et identifié par la dimension nominale (diamètre de sortie) et par la gamme de collecteurs sur lesquels il peut être soudé.

#### Standard - XS

		Outlet size - Diamètre sortie												
		1/8"	1/4"	3/8"	1/2"	3/4"	1"	1" 1/4	1" 1/2	2"	2" 1/2	3"	4"	6"
Run sizes Dimensions collecteurs	3/8"	3/8"	1/2"	1/2"	3/4"	1"	1" 1/4	1" 1/2	2"	2" 1/2	3"	4"	6"	
	1/2"	1/2"	1" - 3/4"	3/4"	1"	1" 1/4	1" 1/2	2"	2" 1/2	3"	3" 1/2	5"	8"	
	1" - 3/4"	1" - 3/4"	2" 1/2 - 1" 1/4	1"	1" 1/2 - 1" 1/4	1" 1/2	2"	2" 1/2	3"	3" 1/2	4"	6"	10"	
	2" 1/2 - 1" 1/4	2" 1/2 - 1" 1/4	36" - 3"	1" 1/2 - 1" 1/4	2" 1/2 - 2"	2"	2" 1/2	3"	4"	4"	5"	8"	14" - 12"	
	36" - 3"	36" - 3"		2" 1/2 - 2"	5" - 3"	2" 1/2	3" 1/2 - 3"	4" - 3" 1/2	5"	5"	6"	10"	16"	
				8" - 3"	12" - 6"	3" 1/2 - 3"	5" - 4"	6" - 5"	6"	6"	8"	14" - 12"	18"	
				36" - 10"	36" - 14"	5" - 4"	8" - 6"	12" - 8"	10" - 8"	8"	10"	20" - 16"	22" - 20"	
						10" - 6"	18" - 10"	24" - 14"	18" - 12"	12" - 10"	14" - 12"	36" - 24"	28" - 24"	
						36" - 12"	36" - 20"	36" - 26"	36" - 20"	18" - 14"	20" - 16"		36" - 30"	
										36" - 20"	36" - 24"			

#### SCH 160 - XXS

		Outlet size - Diamètre sortie					
		1/2"	3/4"	1"	1" 1/4	1" 1/2	2"
Run sizes Dimensions collecteurs	1/2"	1/2"	1" - 3/4"	1"	1" 1/2 - 1" 1/4	1" 1/2	2"
	1" 1/4 - 3/4"		2" - 1" 1/4	2" - 1" 1/4	2" 1/2 - 2"	2" 1/2 - 2"	2" 1/2
	36" - 1" 1/2		6" - 2" 1/2	10" - 3"	10" - 3"	3" 1/2 - 3"	3" 1/2 - 3"
			36" - 8"	36" - 12"	36" - 12"	8" - 4"	5" - 4"
						20" - 10"	8" - 6"
						36" - 24"	18" - 10"
							36" - 20"

## WELD-OUTLET STANDARD (STD)



**Reducing size**  
*Pièces réduites*

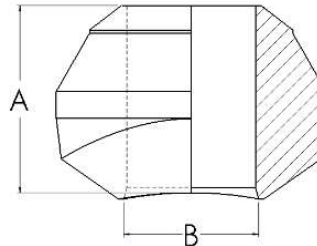

**Full size**  
*Pièces égales*

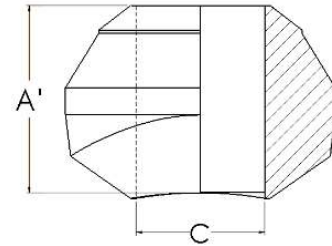

BW end per ANSI B16.25

Sch: STD / XS / 160 & XXS

Size: 1/4" to 60"

Dimensions according to MSS-SP97

Nom. size dimension Dim. Nom.	TYPE I					TYPE II				
	A <sup>(1)</sup>		B		Weight / poids	A' <sup>(1)</sup>		C		Weight / poids
	Inches	mm	Inches	mm	kg	Inches	mm	Inches	mm	kg
1/8"	0.62	15,7	0.62	16,0	0.04					
1/4"	0.62	15,7	0.62	16,0	0.04					
3/8"	0.75	19,1	0.75	19,0	0.07					
1/2"	0.75	19,1	0.94	23,8	0.08	0.75	19,1	0.62	15,76	0.07
3/4"	0.88	22,4	1.18	30,0	0.12	0.88	22,4	0.83	20,96	0.12
1"	1.06	26,9	1.43	36,5	0.22	1.06	26,9	1.05	26,64	0.18
1"1/4"	1.25	31,8	1.75	44,5	0.36	1.25	31,8	1.38	35,08	0.32
1"1/2"	1.31	33,3	2.00	50,8	0.45	1.31	33,3	1.61	40,94	0.36
2"	1.50	38,1	2.56	65,0	0.80	1.50	38,1	2.06	52,48	0.70
2"1/2"	1.62	41,1	3.00	76,2	1.15	1.62	41,1	2.47	62,68	1.10
3"	1.75	44,4	3.68	93,7	1.80	1.75	44,4	3.07	77,92	1.70
3"1/2"	1.88	47,8	4.00	101,6	2.50	2.00	50,8	3.55	90,12	2.25
4"	2.00	50,8	4.75	120,7	2.90	2.00	50,8	4.03	102,26	3.05
5"	2.25	57,2	5.56	141,0	4.60	2.25	57,2	5.05	128,20	4.85
6"	2.38	60,4	6.61	168,0	7.00	2.38	60,4	6.07	154,08	7.50
8"	2.75	69,8	8.58	218,0	12.00	2.75	69,8	7.98	202,74	12.70
10"	3.06	77,7	10.71	272,0	19.50	3.06	77,7	10.02	254,46	20.00
12"	3.38	85,9	12.72	323,0	26.70	3.38	85,9	12.00	304,84	29.40
14"	3.50	88,9	14.06	357,0	29.90	3.50	88,9	13.25	336,54	31.80
16"	3.69	93,7	16.06	408,0	34.00	3.69	93,7	15.25	387,34	41.70
18"	3.81	96,8	17.91	455,0	44.00	4.06	103,1	17.25	438,14	56.70
20"	4.00	101,6	20.06	510,0	53.50	4.62	117,3	19.25	488,94	79.30
24"	4.56	115,8	24.01	610,0	99.70	5.38	136,6	23.25	590,54	127.00

Up to and including 10", dimensions are the same for SCHED STD & 40 outlets. For 12" and over : on request

Jusqu'au 10", les dimensions sont identiques pour olets SCHED STD & 40. A partir de 12" : sur demande

<sup>(1)</sup> Tolérances sur A / A Tolerances : 1/8" - 3/4" : -0.8mm max - 1" - 4" : -1.6mm max / 5" - 12" : -3.2mm max / 14" - 24" : -4.8mm max

Type I and Type II at manufacturer option. If spécifie B and C dimension request, please contact us.

## LIGHT WEIGHT-OUTLET

Rating: CL 300

Sch: 5S / 10S

Size: from 1/4" to 48"  
larger sizes

available on application

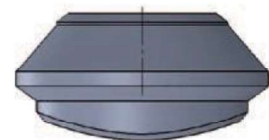

## WELD-OUTLET EXTRA STRONG (XS)

Nom. size dimension Dim. Nom.	Reducing size - pièces réduites					Full size - Pièces égales				
	A <sup>(1)</sup>		B		Weight - poids	A <sup>(1)</sup>		C		Weight - poids
	Inches	mm	Inches	mm	Kg	Inches	mm	Inches	mm	Kg
1/8"	0.62	15,7	0.63	16,0	0.04					
1/4"	0.62	15,7	0.63	16,0	0.04					
3/8"	0.75	19,1	0.75	19,0	0.07					
1/2"	0.75	19,1	0.94	23,8	0.09	0.75	19,1	0.54	13,84	0.07
3/4"	0.88	22,4	1.18	30,0	0.14	0.88	22,4	0.74	18,88	0.12
1"	1.06	26,9	1.44	36,5	0.21	1.06	26,9	0.96	24,30	0.18
1 1/4"	1.25	31,8	1.75	44,5	0.40	1.25	31,8	1.28	32,50	0.32
1 1/2"	1.31	33,3	2.00	50,8	0.50	1.31	33,3	1.50	38,14	0.40
2"	1.50	38,1	2.56	65,0	0.79	1.50	38,1	1.94	49,20	0.72
2 1/2"	1.62	41,1	3.00	76,2	1.18	1.62	41,1	2.32	58,98	1.13
3"	1.75	44,4	3.69	93,7	1.85	1.75	44,4	2.90	73,70	1.85
3 1/2"	1.88	47,8	4.00	101,6	2.54	2.00	50,8	3.36	85,40	2.30
4"	2.00	50,8	4.75	120,7	2.90	2.00	50,8	3.83	97,18	3.40
5"	2.25	57,2	5.55	141,0	4.70	2.25	57,2	4.81	122,24	5.00
6"	2.38	77,7	6.61	168,0	10.40	3.06	77,7	5.76	146,36	10.40
8"	2.75	98,6	8.68	220,5	20.40	3.88	98,6	7.63	193,70	21.00
10"	3.06	93,7	10.43	265,0	24.80	3.50	88,9	9.75	247,60	25.40
12"	3.38	103,1	12.44	316,0	35.00	3.94	100,1	11.75	298,50	35.00
14"	3.50	100,1	13.81	351,0	37.00	4.12	104,6	13.00	330,20	39.00
16"	3.69	106,2	15.86	403,0	46.20	4.44	112,8	15.00	381,00	52.00
18"	3.81	111,2	17.91	455,0	58.90	4.69	119,1	17.00	431,80	59.00
20"	4.00	119,1	20.08	510,0	71.50	5.00	127,0	19.00	482,60	84.70
24"	4.56	139,7	24.02	610,0	141.00	5.50	139,7	23.00	584,20	146.00

Up to and including 8", dimensions are the same for SCHED XS & 80 outlets. For 10" and over : on request

Jusqu'à 8", les dimensions sont identiques pour olets SCHED XS & 80. A partir de 10" : sur demande

<sup>(1)</sup> Tolérances sur A - A Tolérances : 1"-8" - 3/4" : -0.8mm max - 1"- 4" : -1.6mm max - 5"- 12" : -3.2mm max - 14"- 24" : -4.8mm max

## WELD-OUTLET SH 160 / XXS

Nom. size dimension Dim. Nom.	Reducing size - pièces réduites					Full size - Pièces égales				
	A <sup>(1)</sup>		B		Weight - poids	A <sup>(1)</sup>		C <sup>(2)</sup>		Weight - poids
	Inches	mm	Inches	mm	kg	Inches	mm	Inches	mm	kg
1/2"	1.12	28,4	0.55	14,0	0.15	1.12	28,4	0.46	11,74	0.15
3/4"	1.25	31,8	0.75	19,0	0.32	1.25	31,8	0.61	15,58	0.32
1"	1.50	38,1	1.00	25,4	0.38	1.50	38,1	0.81	20,70	0.38
1 1/4"	1.75	44,4	1.31	33,3	0.55	1.75	44,4	1.16	29,50	0.60
1 1/2"	2.00	50,8	1.50	38,0	0.80	2.00	50,8	1.34	34,02	0.85
2"	2.18	55,4	1.68	42,8	0.97	2.18	55,4	1.69	42,82	1.00
2 1/2"	2.44	62,0	2.12	54,0	1.55	2.44	62,0	2.12	53,94	1.70
3"	2.88	73,2	2.87	73,0	2.85	2.88	73,2	2.62	66,64	2.95
4"	3.31	84,1	3.87	98,5	4.75	3.31	84,1	3.44	87,32	4.95
5"	3.69	93,7	4.81	122,0	6.50	3.69	93,7	4.31	109,54	6.80
6"	4.12	104,6	5.67	144,0	12.7	4.12	104,6	5.18	131,78	13.70

Outlets sizes listed in the chart are suitable for Sch.160 and XXS. For 8" outlet and over, always specify run pipe thickness

Les dimensions d'olets listés sont disponibles pour les diamètres de collecteurs en Sch.160 et XXS. A partir de 8", il convient de toujours préciser l'épaisseur

Suitable for Sch 160 run pipe - Dimensions pour collecteurs Sch 160

<sup>(2)</sup> For Sch.160

We reserve the right to supply as per manufacturer standard

**SOCKET WELDING FITTINGS**

*Raccords emboîtés soudés*

**SOCK-OUTLET**

SW end per ANSI B16.11  
Rating: 3000 / 6000 / 9000 /  
Size: from 1/8" to 4"

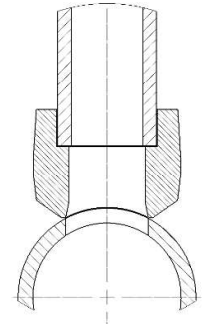
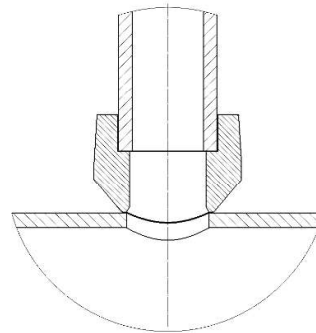

**THREADED FITTINGS**

*Raccords taraudés*

**THREAD-OUTLET**

NPT end per ANSI B1.20.1  
Size: from 1/8" to 4"  
Rating: 3000 / 6000  
9000 / 10000 on request

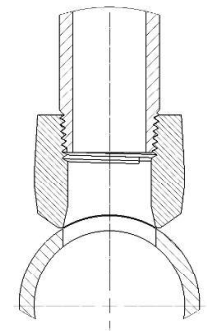
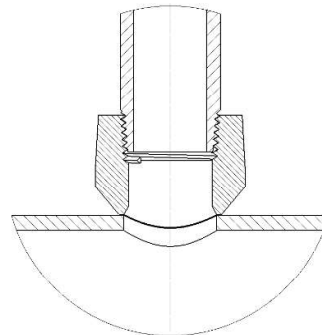

Class 3000

	Outlet size - Diamètre sortie											
	1/8"	1/4"	3/8"	1/2"	3/4"	1"	1" 1/4	1" 1/2	2"	2" 1/2	3"	4"
Run sizes / Dimensions collecteurs	3/8"	3/8"	1/2"	1/2"	3/4"	1"	1" 1/4	1" 1/2	2"	2" 1/2	3"	4"
	1/2"	1/2"	3/4" - 1"	3/4"	1"	1" 1/4	1" 1/2	2"	2" 1/2	3"	3" 1/2	5"
	3/4" - 1"	3/4" - 1"	1" 1/4 - 2" 1/2	1"	1" 1/4 - 1" 1/2	1" 1/2	2"	2" 1/2	3"	3" 1/2	4"	6"
	1" 1/4 - 2" 1/2	1" 1/4 - 2" 1/2	3" - 36"	1" 1/4 - 1" 1/2	2" - 2" 1/2	2"	2" 1/2	3"	4"	4"	5"	8"
	3" - 36"	3" - 36"		2" - 2" 1/2	3" - 5"	2" 1/2	3" - 3" 1/2	3" 1/2 - 4"	5"	5"	6"	10"
				3" - 8"	6" - 12"	3" - 3" 1/2	4" - 5"	5" - 6"	6"	6"	8"	12" - 14"
				10" - 36"	14" - 36"	4" - 5"	6" - 8"	8" - 12"	8" - 10"	8"	10"	16" - 20"
						6" - 10"	10" - 18"	14" - 24"	12" - 18"	10" - 12"	12" - 14"	24" - 36"
						12" - 36"	20" - 36"	26" - 36"	20" - 36"	14" - 18"	16" - 20"	
										20" - 36"	24" - 36"	

Class 6000

	Outlet size / Diamètre sortie					
	1/2"	3/4"	1"	1" 1/4	1" 1/2	2"
Run sizes / Dimensions collecteurs	3/4" - 1"	1"	1" 1/4 - 1" 1/2	1" 1/2	2"	2" 1/2
	1" 1/4 - 2"	1" 1/4 - 2" 1/2	2" - 2" 1/2	2" - 2" 1/2	2" 1/2	3"
	2" 1/2 - 6"	3" - 10"	3" - 10"	3" - 3" 1/2	3" - 3" 1/2	4"
	8" - 36"	12" - 36"	12" - 36"	4" - 8"	4" - 5"	5"
				10" - 20"	6" - 8"	6"
				24" - 36"	10" - 18"	8" - 10"
					20" - 36"	12" - 20"
						24" - 36"

## SOCK-OUTLET



**Reducing size**  
Pièces réduites

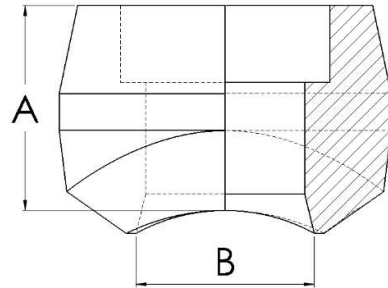

**Full size**  
Pièces égales

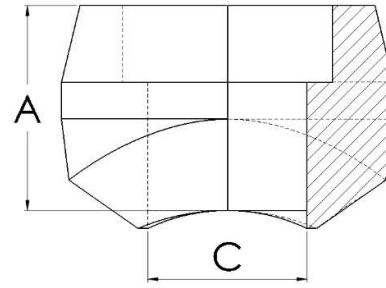

### Class 3000

Nom. size dimension Dim. Nom.	Reducing size - pièces réduites					Full size - Pièces égales		
	A		B		Weight - poids kg	C <sup>(1)</sup>		Weight - poids kg
	Inches	mm	Inches	mm		Inches	mm	
1/8	0.75	19,0	0.63	16,0	0,06			
1/4	0.75	19,0	0.61	15,6	0,06			
3/8	0.81	20,6	0.75	19,0	0,09			
1/2	1.00	25,4	0.94	23,8	0,11	0.55	14,0	0,12
3/4	1.06	27,0	1.18	30,0	0,17	0.75	19,0	0,19
1	1.31	33,3	1.44	36,5	0,29	0.94	24,0	0,31
1 1/4	1.31	33,3	1.75	44,5	0,41	1.26	32,0	0,45
1 1/2	1.38	35,0	2.00	50,8	0,46	1.50	38,0	0,50
2	1.50	38,0	2.56	65,0	0,80	1.93	49,0	0,87
2 1/2	1.81	46,0	3.00	76,0	1,40	2.32	59,0	1,50
3	2.00	50,8	3.69	93,7	2,00	2.89	73,5	2,15
3 1/2	2.13	54,0	4.00	101,5	2,60	3.35	85,0	2,80
4	2.25	57,2	4.75	120,7	3,30	3.82	97,0	3,50

<sup>(1)</sup> Suitable for STD & XS run pipe WT - Raccordement pour tube sch std & xs

### Class 6000

Nom. size dimension Dim. Nom.	Reducing size - pièces réduites				
	A		B		Weight - poids kg
	Inches	mm	Inches	mm	
1/4	1.12	28,5	0.55	14,0	0,20
3/8	1.12	28,5	0.55	14,0	0,20
1/2	1.26	32,0	0.75	19,0	0,30
3/4	1.44	36,5	1.00	25,4	0,50
1	1.56	39,5	1.31	33,4	0,90
1 1/4	1.62	41,1	1.50	38,0	0,85
1 1/2	1.69	43,0	1.87	47,5	1,45
2	2.07	52,5	2.32	59,0	2,75

Suitable for 160 run pipe WT - Raccordement pour tube sch 160

### Class 9000

Nom. size dimension Dim. Nom.	Pièces réduites-reducing size				
	A		B		Weight - poids kg
	Inches	mm	Inches	mm	
1/2"	1.26	32,0	0.75	19,0	0,32
3/4"	1.44	36,5	1.00	25,4	0,55
1"	1.56	39,5	1.31	33,4	0,95
1 1/2"	1.69	43,0	1.87	47,5	1,50
2"	2.07	52,5	2.32	59,0	2,90

Suitable for XXS run pipe WT- Raccordement pour tube sch XXS

## THREAD OUTLET

### Raccord taraudé



#### Reducing size

Pièces réduites

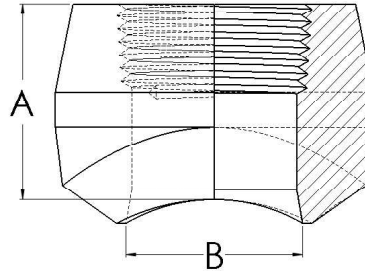

#### Full size

Pièces égales

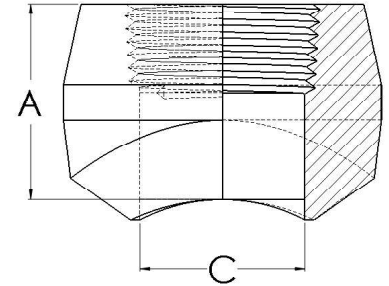

### Class 3000

Nom. size Dim. Nom.	Reducing size - pièces réduites					Full size - Pièces égales		
	A <sup>(1)</sup>		B		Weight - poids kg	C <sup>(2)</sup>		Weight - poids kg
	Inches	mm	Inches	mm		Inches	mm	
1/8"	0.75	19,0	0.63	16,0	0,06			
1/4"	0.75	19,0	0.61	15,6	0,06			
3/8"	0.81	20,6	0.75	19,0	0,09			
1/2"	1.00	25,4	0.94	23,8	0,11	0.71	18,0	0,12
3/4"	1.06	26,9	1.18	30,0	0,17	0.91	23,0	0,19
1"	1.31	33,3	1.44	36,5	0,29	1.10	28,0	0,31
1" 1/4	1.31	33,3	1.75	44,5	0,41	1.50	38,0	0,45
1" 1/2	1.38	35,0	2.00	50,8	0,46	1.69	43,0	0,50
2"	1.50	38,1	2.56	65,0	0,80	2.16	55,0	0,87
2" 1/2	1.81	46,0	2.99	76,0	1,74	2.59	65,7	1,50
3"	2.00	50,8	3.69	93,7	2,00	3.19	81,1	2,15
4"	2.25	57,2	4.75	120,7	3,35	4.20	106,8	3,60

### Class 6000

	Reducing size - pièces réduites				
	A <sup>(1)</sup>		B		Weight - poids kg
	Inches	mm	Inches	mm	
1/2"	1.25	31,8	0.71	18,0	0,30
3/4"	1.44	36,6	0.91	23,0	0,50
1"	1.56	39,6	1.10	28,0	0,90
1" 1/4	1.62	41,1	1.50	38,0	0,85
1" 1/2	1.69	42,3	1.69	43,0	1,45
2"	2.06	52,3	2.16	55,0	2,75

<sup>(1)</sup> Dimensions not listed in MSS SP 97-- *Dimensions non reprises dans MSS SP97*

<sup>(2)</sup> Suitable for STD and XS run pipe sizes - *Dimensions appropriées pour collecteurs épaisseurs STD et XS*

## JD-OUTLET

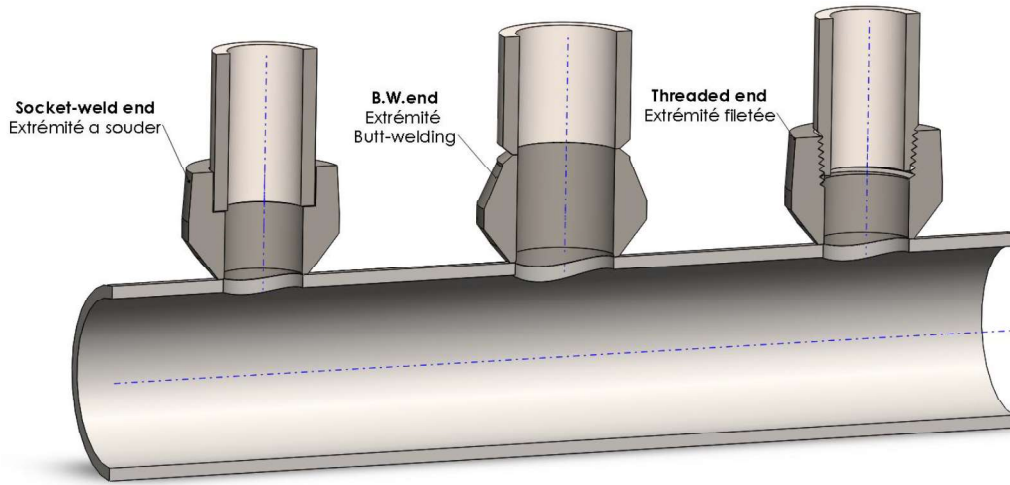

### Description: JD OUTLET (Flex Type) – SW / NPT / BSP / BW

Class : 3000 Lbs – 6000Lbs – 9000Lbs – 10 000Lbs

Schedule : From Sh10 to XXS (Spécial Well Thicknesses as well/Epaisseurs spéciales disponibles)

JD OUTLET (Flex Type) reduces the number of references.  
Advantages are: fewer inventory items to keep in stock, orders filled faster. These items are available in BW, NPT, BSP or SW.

*Les JD OUTLET (Flex Type) réduisent le nombre de références. Les avantages sont : moins d'items à stocker et des préparations de commandes facilitées. Ces Outlets sont disponibles en BW, NPT, BSP ou SW.*

Example :

JD SOCK-OUTLET (FLEX) 3M 1" x 1"1/4 – 2"1/2

#### JD SOCK-OUTLET (FLEX)

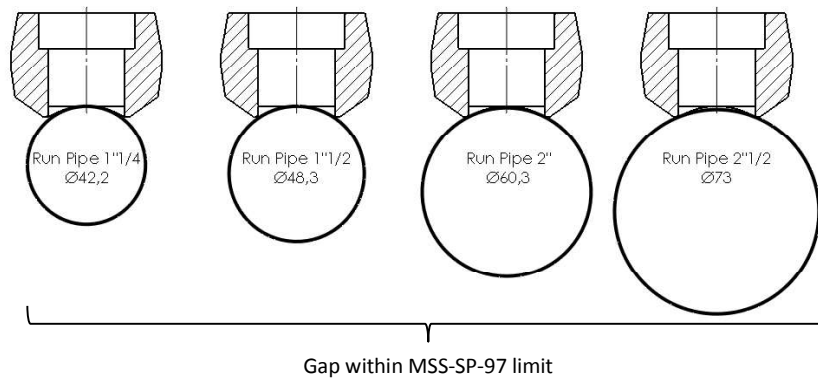

#### JD SOCK-OUTLET (Classic)

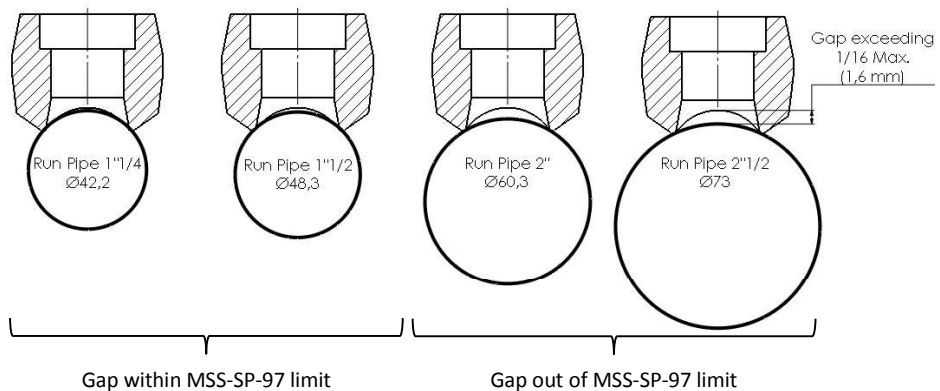

## JD-OUTLET

BW / SW / NPT end per B16.25 / B16.11 / B1.20.1  
 Rating: 3000 / 6000 / 9000  
 BW Sch: 10 / STD / XS / 160 & XXS  
 Size: from 1/4" to 4"  
 Other sizes on request

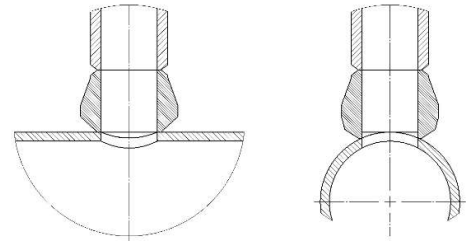

## FLEX RUN-PIPE

### STD – XS JD WELD-OUTLETS

Run sizes Dimensions collecteurs	Outlet size - Diamètre sortie										
	1/4"	3/8"	1/2"	3/4"	1"	1" 1/4	1" 1/2	2"	2" 1/2	3"	4"
<b>STD</b>											
	3/8" – 36"	3/8" – 1/2"	1/2" – 1"	3/4" – 2"	1" 1/4 – 1" 1/2	1" 1/2 – 2"	2" – 3" 1/2	2" 1/2 – 3"	3" – 4"	3" 1/2 – 4"	5" – 6"
		3/4" – 36"	1" 1/4 – 36"	2" 1/2 – 36"	2" – 36"	2" 1/2 – 6"	4" – 36"	3" 1/2 – 6"	5" – 10"	5" – 6"	8" – 10"
						8" – 36"		8" – 36"	12" – 36"	8" – 14"	12" – 20"
										16" – 36"	22" – 36"
<b>XS</b>											
	1/4" – 36"	1/2" – 36"	1/2" – 3/4"	3/4" – 1" 1/2	1" 1/4 – 1" 1/2	1" 1/4 – 2"	2" – 3" 1/2	2" 1/2 – 3"	3" – 4"	3" 1/2 – 4"	5" – 6"
			1" – 36"	2" – 36"	2" – 36"	2" 1/2 – 5"	4" – 36"	3" 1/2 – 6"	5" – 10"	5" – 6"	8" – 10"
						6" – 36"		8" – 36"	12" – 36"	8" – 14"	12" – 20"
										16" – 36"	22" – 36"

### Sch 160 – XXS JD WELD-OUTLETS

Run sizes Dimensions collecteurs	Outlet size - Diamètre sortie			
	3/4"	1"	1" 1/4	1" 1/2
	1" – 36"	1" 1/4 – 36"	2" – 36"	2" – 2" 1/2
				3" – 36"
				8" – 36"

### Class 3000 – 6000 – 9000 JD SOCK - OUTLETS

Run sizes Dimensions collecteurs	Outlet size - Diamètre sortie										
	1/4"	3/8"	1/2"	3/4"	1"	1" 1/4	1" 1/2	2"	2" 1/2	3"	4"
<b>3000</b>											
	3/8" – 36"	3/8" – 1/2"	3/4" – 36"	3/4" – 1" 1/4	1" 1/4 – 2" 1/2	1" 1/4 – 1" 1/2	2" – 2" 1/2	2" 1/2 – 3" 1/2	3" – 3" 1/2	3" 1/2 – 5"	5" – 6"
		3/4" – 36"		1" 1/2 – 36"	3" – 36"	2" – 3" 1/2	3" – 5"	4" – 6"	4" – 6"	6" – 14"	8" – 10"
						4" – 36"	6" – 36"	8" – 36"	8" – 36"	16" – 36"	12" – 20"
											22" – 36"
<b>6000 - 9000</b>											
	1/4" – 36"	3/8" – 36"	3/4" – 36"	3/4" – 1"	1" 1/4 – 2" 1/2	1" 1/2 – 4"	2" – 2" 1/2	2" 1/2 – 3" 1/2	2" 1/2 – 3"	3" – 3" 1/2	5"
				1" 1/4 – 36"	3" – 36"	5" – 36"	3" – 5"	4" – 6"	3" 1/2 – 5"	4" – 5"	6" – 8"
							6" – 36"	8" – 36"	6" – 18"	6" – 10"	10" – 14"
									20" – 36"	12" – 26"	16" – 36"
										28" – 36"	

### Class 3000 – 6000 JD THREAD - OUTLETS

Run sizes Dimensions collecteurs	Outlet size - Diamètre sortie										
	1/4"	3/8"	1/2"	3/4"	1"	1" 1/4	1" 1/2	2"	2" 1/2	3"	4"
<b>3000</b>											
	1/4" – 3/8"	3/8" – 1"	3/4" – 36"	3/4" – 1" 1/4	1" 1/4 – 2" 1/2	1" 1/4 – 1" 1/2	2" – 2" 1/2	2" 1/2 – 3" 1/2	3" – 3" 1/2	3" 1/2 – 5"	5" – 6"
	1/2" – 36"	1" 1/4 – 36"		1" 1/2 – 36"	3" – 36"	2" – 3" 1/2	3" – 5"	4" – 6"	4" – 6"	6" – 14"	8" – 10"
						4" – 36"	6" – 36"	8" – 36"	8" – 36"	16" – 36"	12" – 20"
											22" – 36"
<b>6000</b>											
	1/4" – 3/8"	3/8" – 1"	3/4" – 36"	1" – 1" 1/4	1" 1/4 – 2" 1/2	1" 1/4 – 1" 1/2	2" – 2" 1/2	2" 1/2 – 3" 1/2	3" – 3" 1/2	3" 1/2	5"
	1/2" – 36"	1" 1/4 – 36"		1" 1/2 – 36"	3" – 36"	2" – 3" 1/2	3" – 5"	4" – 6"	4" – 5"	4"	6"
						4" – 8"	6" – 36"	8" – 36"	6" – 10"	5" – 6"	8" – 10"
						10" – 36"			12" – 26"	8" – 12"	12" – 18"
									28" – 36"	14" – 36"	20" – 36"



## JD-OUTLET FOR RUN PIPES UP TO 80"

BW / SW / NPT end per B16.25 / B16.11 / B1.20.1  
 Rating: 3000 / 6000 / 9000  
 BW Sch: 10 / STD / XS / 160 & XXS  
 Size: from 1/4" to 4"  
 Other sizes on request

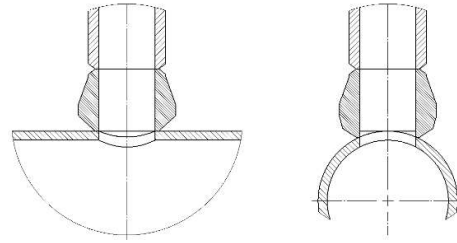

### FLEX RUN-PIPE

#### STD – XS JD WELD-OUTLETS

		Outlet size - Diamètre sortie										
		1/4"	3/8"	1/2"	3/4"	1"	1" 1/4	1" 1/2	2"	2" 1/2	3"	4"
Run sizes Dimensions collecteurs	STD - XS											
	3/8" – 80"	1/2" – 80"	3/4" – 80"	1" – 2" 1/2	1" 1/4 – 2" 1/2	1" 1/2 – 2"	2" – 2" 1/2	2" 1/2 – 3"	3" – 4"	3" 1/2 – 4"	5"	
				3" – 80"	3" – 80"	2" 1/2 – 6"	3" – 6"	3" 1/2 – 6"	6" – 14"	5"	6"	
						8" – 80"	8" – 80"	8" – 80"	16" – 80"	6" – 8"	8" – 10"	
										10" – 24"	12" – 20"	
									26" – 80"	22" – 72"		

#### Sch 160 – XXS JD WELD-OUTLETS

		Outlet size - Diamètre sortie										
		1/4"	3/8"	1/2"	3/4"	1"	1" 1/4	1" 1/2	2"	2" 1/2	3"	4"
Run sizes Dimensions collecteurs	160 - XXS											
	3/8" – 80"	1/2" – 80"	3/4" – 80"	1" – 80"	1" 1/4 – 80"	1" 1/2 – 2"	2" – 3" 1/2	2" 1/2 – 4"	2" 1/2 – 3"	3" 1/2 – 4"	6" – 8"	
						2" 1/2 – 80"	4" – 80"	6" – 80"	3" 1/2 – 6"	6" – 10"	10" – 16"	
									8" – 80"	12" – 80"	18" – 80"	

#### Class 3000 – 6000 – 9000 JD SOCK - OUTLETS

		Outlet size - Diamètre sortie										
		1/4"	3/8"	1/2"	3/4"	1"	1" 1/4	1" 1/2	2"	2" 1/2	3"	4"
Run sizes Dimensions collecteurs	3000											
	3/8" – 80"	1/2" – 80"	3/4" – 80"	1" – 2" 1/2	1" 1/4 – 2" 1/2	1" 1/2 – 2"	2" – 2" 1/2	2" 1/2 – 3"	3" – 4"	3" 1/2 – 4"	5"	
				3" – 80"	3" – 80"	2" 1/2 – 6"	3" – 6"	3" 1/2 – 6"	6" – 14"	5"	6"	
						8" – 80"	8" – 80"	8" – 80"	16" – 80"	6" – 8"	8" – 10"	
										10" – 24"	12" – 20"	
										26" – 80"	22" – 72"	
		6000 - 9000										
	3/8" – 80"	1/2" – 80"	3/4" – 80"	1" – 80"	1" 1/4 – 80"	1" 1/2 – 2"	2" – 3" 1/2	2" 1/2 – 4"	2" 1/2 – 3"	3" 1/2 – 4"	6" – 8"	
						2" 1/2 – 80"	4" – 80"	6" – 80"	3" 1/2 – 6"	6" – 10"	10" – 16"	
									8" – 80"	12" – 80"	18" – 80"	

#### Class 3000 – 6000 JD THREAD - OUTLETS

		Outlet size - Diamètre sortie										
		1/4"	3/8"	1/2"	3/4"	1"	1" 1/4	1" 1/2	2"	2" 1/2	3"	4"
Run sizes Dimensions collecteurs	3000											
	3/8" – 80"	1/2" – 80"	3/4" – 80"	1" – 2" 1/2	1" 1/4 – 2" 1/2	1" 1/2 – 2"	2" – 2" 1/2	2" 1/2 – 3"	3" – 4"	3" 1/2 – 4"	5"	
				3" – 80"	3" – 80"	2" 1/2 – 6"	3" – 6"	3" 1/2 – 6"	6" – 14"	5"	6"	
						8" – 80"	8" – 80"	8" – 80"	16" – 80"	6" – 8"	8" – 10"	
										10" – 24"	12" – 20"	
										26" – 80"	22" – 72"	
		6000										
	3/8" – 80"	1/2" – 80"	3/4" – 80"	1"	1" 1/2 – 2"	1" 1/2	2"	2" 1/2 – 3"	3"	3" 1/2 – 4"	6"	
				1" 1/4 – 80"	2" 1/2 – 80"	2" – 3" 1/2	2" 1/2 – 4"	3" 1/2 – 6"	3" 1/2 – 4"	6"	8"	
						4" – 80"	6" – 80"	8" – 80"	6" – 10"	8" – 14"	10" – 12"	
								12" – 80"	16" – 80"	14" – 22"		
										24" – 80"		

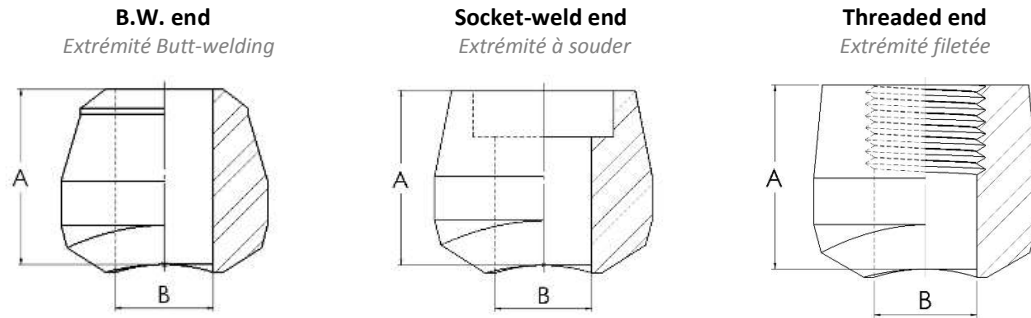

**BUTT JD-OUTLET Standard – XS**

Nom. size dimension Dim. Nom.	STD - XS		STD			XS		
	A		B		Weight - poids	B		Weight - poids
	Inches	mm	Inches	mm	kg	Inches	mm	kg
1/2"	0.75	19,1	0.62	15,76	0,09	0.54	13,84	0,10
3/4"	0.88	22,4	0.83	20,96	0,13	0.74	18,88	0,14
1"	1.06	26,9	1.05	26,64	0,24	0.96	24,30	0,25
1"1/4	1.25	31,8	1.38	35,08	0,28	1.28	32,50	0,32
1"1/2	1.31	33,3	1.61	40,94	0,36	1.50	38,14	0,40
2"	1.50	38,1	2.07	52,48	0,73	1.94	49,22	0,78
3"	1.75	44,4	3.07	77,92	1,34	2.90	73,66	1,48
4"	2.00	50,8	4.03	102,26	1,88	3.83	97,18	2,00

**BUTT JD-OUTLET Sch 160 – XXS**

Nom. size dimension Dim. Nom.	160 - XXS				
	A		B		Weight - poids
	Inches	mm	Inches	mm	kg
3/4"	1.25	31,8	0.61	15,58	0,21
1"	1.50	38,1	0.81	20,70	0,31
1"1/4	1.75	44,4	1.16	29,50	0,38
1"1/2	2.00	50,8	1.34	34,02	0,47
2"	2.18	55,4	1.69	42,82	0,88

**SOCK JD-OUTLET**

Nom. size dimension Dim. Nom.	3000					6000 - 9000				
	A		B		Weight - poids	A		B		Weight - poids
	Inches	mm	Inches	mm	kg	Inches	mm	Inches	mm	kg
1/2"	1.00	25,4	0.592	15,0	0,13	1.25	32,0	0.434	11,0	0,30
3/4"	1.06	27,0	0.794	22,2	0,17	1.44	36,5	0.582	14,8	0,38
1"	1.31	33,3	1.019	25,9	0,32	1.56	39,5	0.785	19,9	0,63
1"1/4	1.31	33,3	1.350	34,3	0,46	1.62	41,1	1.130	28,7	0,82
1"1/2	1.38	35,0	1.580	40,1	0,57	1.69	43,0	1.308	33,2	0,98
2"	1.50	38,0	2.037	51,7	0,77	2.06	52,5	1.657	42,1	1,41

**THREAD JD-OUTLET**

Nom. size dimension Dim. Nom.	3000					6000				
	A		B		Weight - poids	A		B		Weight - poids
	Inches	mm	Inches	mm	kg	Inches	mm	Inches	mm	kg
1/2"	1.00	25,4	0.71	18	0,13	1.25	31,8	0.71	18	0,28
3/4"	1.06	26,9	0.91	23	0,17	1.44	36,6	0.91	23	0,36
1"	1.31	33,3	1.10	28	0,33	1.56	39,6	1.10	28	0,60
1"1/4	1.31	33,3	1.50	38	0,48	1.62	41,1	1.50	38	0,78
1"1/2	1.38	35,0	1.69	43	0,59	1.69	42,3	1.69	43	0,95
2"	1.50	38,1	2.17	55	0,80	2.06	52,3	2.17	55	1,37

## NIP-OUTLET

### Raccord allongé



BW / SW / NPT / PE end per B16.25 / B16.11 / B1.20.1  
 Rating: 3000 / 6000 / 9000  
 BW Sch: STD / XS / 80 / 160 & XXS  
 Size: from 1/2" to 2"  
 Other sizes on request

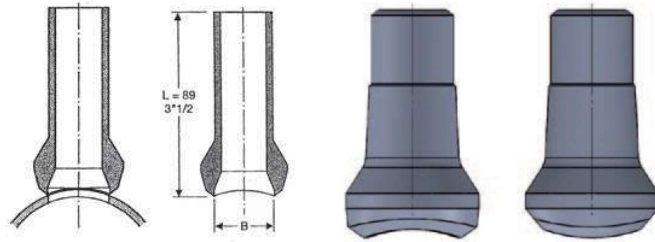

#### Class 3000 - Standard - XS

	Outlet size / Diamètre sortie				
	1/2"	3/4"	1"	1 1/2"	2"
Run sizes Dimensions collecteurs	3" - 1 1/2"	3" - 1 1/2"	1 1/2"	2"	3"
	36" - 4"	36" - 4"	2 1/2" - 2"	3 1/2" - 3"	4" - 3 1/2"
			5" - 3"	5" - 4"	6" - 5"
			36" - 6"	12" - 6"	12" - 8"
			36" - 14"	36" - 14"	

#### Class 6000 - sch 160 - XXS

	Outlet size - Diamètre sortie				
	1/2"	3/4"	1"	1 1/2"	2"
Run sizes Dimensions collecteurs	36" - 1 1/2"	36" - 1 1/2"	4" - 1 1/2"	4" - 2"	4" - 3"
			36" - 6"	36" - 6"	8" - 5"
					36" - 10"

#### Class 3000

Nom. size dimension Dim. Nom.	B		Weight - poids kg
	Inches	mm	
1/4"	0.63	16,0	0,62
3/8"	0.75	19,0	0,75
1/2"	0.94	23,8	0,25
3/4"	1.16	29,5	0,40
1"	1.44	36,5	0,65
1 1/4"	1.75	44,5	0,75
1 1/2"	2.00	50,8	0,95
2"	2.56	65,0	1,45

#### Class 6000

Nom. size dimension Dim. Nom.	B		Weight - poids kg
	Inches	mm	
1/4"			
3/8"			
1/2"	0.55	14,0	0,25
3/4"	0.75	19,0	0,50
1"	1.00	25,5	0,70
1 1/4"	1.50	38,0	0,88
1 1/2"	1.50	38,0	1,15
2"	1.68	42,8	1,50

- Same length for all sizes - La longueur "L" reste identique quel que soit la dimension
- Class 3000 corresponds to Sch 80 and class 6000 corresponds to Sch 160 - Classe 3000 correspond au Sch 80 et classe 6000 correspond au Sch 160
- XXS on request - XXS sur demande

**ELB-OUTLET**  
*Elbow outlet*

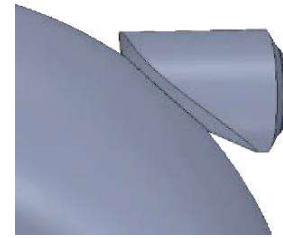

**B.W. end**  
*Extrémité Butt-welding*

**Threaded end**  
*Extrémité filetée*

**Socket-weld end**  
*Extrémité à souder*

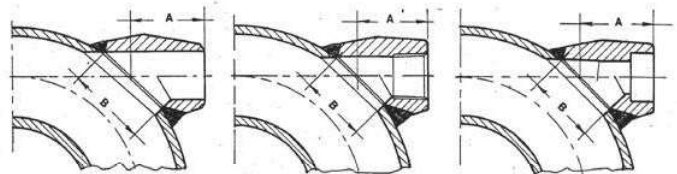

BW / SW / NPT / PE per B16.25 / B16.11 / B1.20.1  
 Rating: 3000 / 6000 / 9000 BW  
 Sch: STD / XS / 160 & XXS  
 Size: from 1/4" to 60"

Nom size dimension Dim. Nom.	3000 lbs - STD WT & XS <sup>(1)</sup>					6000 lbs - Sch 160 & XXS <sup>(1)</sup>				
	A		B		Weight - poids kg	A		B		Weight - poids kg
	Inches	mm	Inches	mm		Inches	mm	Inches	mm	
1/4"	1,61	41,0	1,50	38,0	0,23	1,61	41,0	1,50	38,0	0,35
3/8"	1,61	41,0	1,50	38,0	0,23	1,61	41,0	1,50	38,0	0,35
1/2"	1,61	41,0	1,50	38,0	0,30	1,87	47,5	1,69	43,0	0,40
3/4"	1,87	47,5	1,69	43,0	0,35	2,24	57,0	2,24	57,0	0,67
1"	2,24	57,0	2,24	57,0	0,53	2,50	63,5	2,87	73,0	1,00
1"1/4	2,50	63,5	2,87	73,0	0,86	2,68	68,0	3,13	79,5	1,32
1"1/2	2,75	70,0	3,13	79,5	1,20	3,25	82,5	4,19	106,5	2,80
2"	3,25	82,5	4,19	106,5	2,40	4,00	101,5	4,51	114,5	3,60
2"1/2 to 10"	Available, on request, as butt/welding ends / Disponible, sur demande, en butt/welding									

<sup>(1)</sup> Available only for reduction rate of 2-3 pipe size and over - Disponible seulement pour réduction de diamètre de 2-3 et +

Run sizes Dimensions collecteurs	Class 3000 - Standard - XS / Outlet size - Diamètre sortie		
	1/4" - 3/4"	1" - 1"1/2	2"
	36" - 1"1/4	36" - 2"	36" - 3"

Dimensions collecteurs Run sizes	Class 6000 - sch 160 - XXS / Outlet size - Diamètre sortie		
	1/4" - 1/2"	3/4" - 1"1/4	1"1/2
	36" - 1"1/4	36" - 2"	36" - 3"

## LATERAL OUTLET

### Lateral outlet

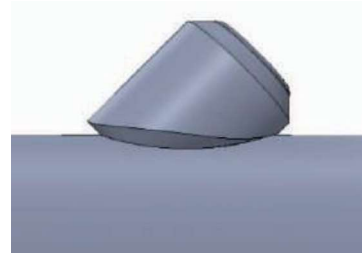

**B.W. end**  
Extrémité Butt-welding

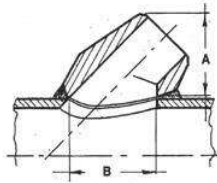

**Threaded end**  
Extrémité fileté

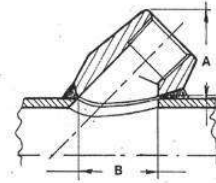

**Socket-weld end**  
Extrémité à souder

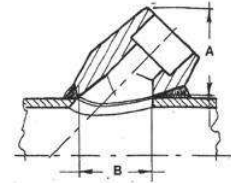

BW / SW / NPT / PE acc. to B16.25/B16.11/B1.20.1  
 FROM 1/4" TO 60"  
 SW & NPT: 3000 / 6000 / 9000  
 BW: STD / XS / 80 / 160 & XXS

Nom. size dimension Dim. Nom.	3000 lbs / STD WT & XS <sup>(1)</sup>					6000 lbs / Sch 160 & XXS <sup>(1)</sup>				
	A (Min. - Max.)		B		Weight/poids kg	A (Min. - Max.)		B		Weight/poids kg
	Inches	mm	Inches	mm		Inches	mm	Inches	mm	
1/4"	1,50 - 1,69	38,1 - 42,9	1,44	36,5	0,23	1,53 - 1,87	38,9 - 47,6	1,44	36,5	0,35
3/8"	1,50 - 1,69	38,1 - 42,9	1,44	36,5	0,23	1,53 - 1,87	38,9 - 47,6	1,44	36,5	0,35
1/2"	1,50 - 1,69	38,1 - 42,9	1,44	36,5	0,30	1,81 - 2,19	46,0 - 55,6	1,75	44,5	0,40
3/4"	1,75 - 2,00	44,5 - 50,8	1,61	41,0	0,35	2,13 - 2,50	54,0 - 63,5	2,13	54,0	0,67
1"	2,12 - 2,56	54,0 - 65,1	2,00	51,0	0,53	2,41 - 2,87	61,1 - 73,0	2,62	66,5	1,00
1 1/4"	2,12 - 2,56	54,0 - 65,1	2,62	66,5	0,86	2,57 - 3,06	65,1 - 77,8	2,99	76,0	1,32
1 1/2"	2,50 - 2,75	63,5 - 69,9	2,87	73,0	1,20	3,09 - 3,37	78,6 - 85,7	4,13	105,0	2,80
2"	2,87 - 3,50	73,0 - 88,9	3,78	96,0	2,40	3,09 - 4,13	78,6 - 104,8	4,37	111,0	3,60
2 1/2 to 10"	Available, on request, as butt/welding ends / Disponible, sur demande, en butt/welding									

Run sizes Dimensions collecteurs	Class 3000 - Standard - XS / Outlet size - Diamètre sortie			
	1/4" - 1/2"	3/4"	1" - 1 1/2"	2"
	2 1/2" - 1 1/4"	1 1/2" - 1 1/4"	2 1/2" - 2"	5" - 4"
	12" - 3"	5" - 2"	5" - 3"	8" - 6"
		12" - 6"	12" - 6"	12" - 10"

Run sizes Dimensions collecteurs	Class 6000 - sch 160 - XXS / Outlet size - Diamètre sortie			
	1/4" - 3/8"	1/2"	3/4" - 1 1/4"	1 1/2"
	2 1/2" - 1 1/4"	1 1/2" - 1 1/4"	2 1/2" - 2"	5" - 4"
	12" - 3"	5" - 2"	5" - 3"	8" - 6"
		12" - 6"	12" - 6"	12" - 10"

## SWEEP-OUTLET

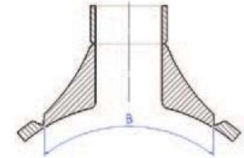
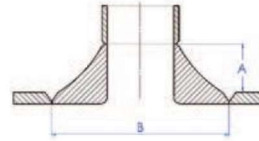
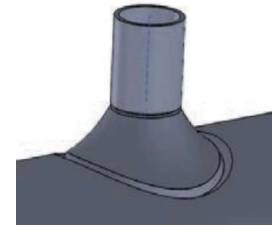

BW end per ANSI B 16.25  
Sch: STD/XS/160 & XXS  
Size: from 1/2" to 48"

BRANCH		DIMENSION A		DIMENSION B	
Inches	mm	Inches	mm	Inches	mm
1"1/2	48,3	1,50	38,1	5,50	139,7
2"	60,3	1,50	38,1	5,50	139,7
3"	88,9	1,65	42,0	7,00	177,8
4"	114,3	2,03	51,6	8,75	222,2
6"	168,3	2,69	68,2	13,00	330,2
8"	219,1	3,00	76,2	15,00	381,0
10"	273,0	3,12	79,3	18,50	469,9
12"	323,9	3,25	82,5	20,50	520,7
14"	355,6	3,50	88,9	24,00	609,6
16"	406,4	3,62	92,0	28,00	711,2
18"	457,2	4,50	114,3	31,00	787,4
20"	508,0	5,00	127,0	33,00	838,2
24"	609,6	5,50	139,7	38,00	965,2

## INSERT WELD-OUTLET

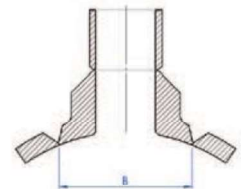
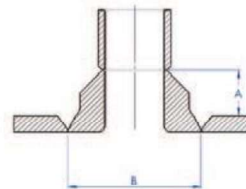
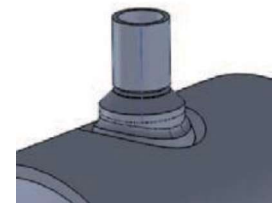

BW end per ANSI B 16.25  
Sch: STD/XS/160 & XXS  
Size: From 1/2" to 48"

BRANCH		DIMENSION A		DIMENSION B	
Inches	mm	Inches	mm	Inches	mm
3/4"	26,7	1,26	32,0	2,36	60,0
1"	33,4	1,26	32,0	2,56	65,0
1"1/2	48,3	1,50	38,1	3,74	95,0
2"	60,3	1,50	38,1	4,33	110,0
2"1/2	73,0	1,62	41,1	4,88	124,0
3"	88,9	1,75	44,5	5,31	135,0
4"	114,3	2,00	50,8	6,89	175,0
5"	141,3	2,25	57,2	8,06	204,7
6"	168,3	2,38	60,5	9,65	245,0
8"	219,1	2,75	69,9	12,99	330,0
10"	273,0	3,06	77,7	14,00	355,6
12"	323,9	3,38	85,9	16,32	414,5
14"	355,6	3,50	88,9	17,56	446,0
16"	406,4	3,75	95,3	19,75	501,6
18"	457,2	3,81	96,8	22,00	558,8
20"	508,0	4,00	101,6	24,00	609,6
24"	609,6	4,56	115,8	29,00	736,6

## INSERT LATERAL OUTLET



BW end per ANSI B 16.25  
Sch: STD/XS/160 & XXS  
Size: From 1/2" to 24"  
Larger sizes available on application

## INSERT FLANGED OUTLET

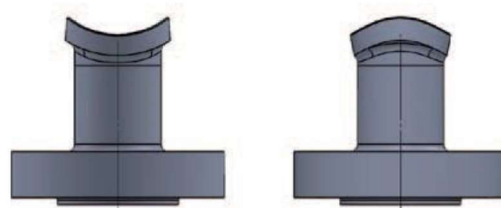

BW end per ASME B16.25 & ASME B16.5  
Size: From 1/2" to 2"  
Larger sizes available on application

## FLANGED NIPPLE OUTLET

Flanged outlet

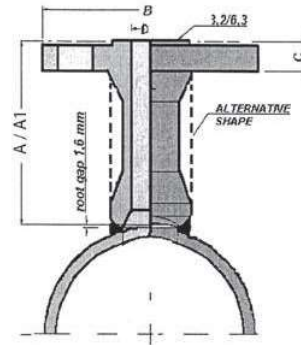
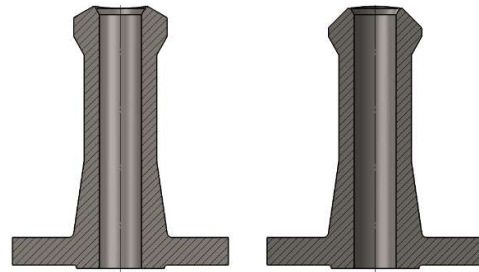

Length A1:  
flanged nip  
Length A:  
flanged weld

ANSI 150					
Branch	dimensions				
	A	A1	B	C	D
1/2"	65	150	90	11,6	bore to be precised
3/4"	75	150	100	13,2	
1"	85	150	110	14,7	
1 1/2"	95	150	125	17,9	
2"	105	150	150	19,5	

ANSI 300					
Branch	dimensions				
	A	A1	B	C	D
1/2"	70	150	95	14,7	bore to be precised
3/4"	80	150	115	16,3	
1"	90	150	125	17,9	
1 1/2"	100	150	155	21,1	
2"	110	150	165	22,7	

ANSI 900 & 1500					
Branch	dimensions				
	A	A1	B	C	D
1/2"	85	150	120	29,3	bore to be precised
3/4"	100	150	130	32,4	
1"	105	150	150	35,6	
1 1/2"	125	150	180	38,8	
2"	145	150	215	45,1	

ANSI 600					
Branch	dimensions				
	A	A1	B	C	D
1/2"	80	150	95	21,3	bore to be precised
3/4"	85	150	115	22,9	
1"	95	150	125	24,5	
1 1/2"	110	150	155	29,3	
2"	120	150	165	32,4	

ANSI 2500					
Branch	dimensions				
	A	A1	B	C	D
1/2"	100	150	135	37,2	bore to be precised
3/4"	110	150	140	38,8	
1"	125	150	160	42,0	
1 1/2"	150	150	205	51,5	
2"	170	165	235	57,9	

Diamètre collecteur Run size	CLASSE - RATING 150 - 300 - 600 - 1500 - Sch. 10 - STD - 40 - XS - 80				
	1/2"	3/4"	1"	1 1/2"	2"
	6" - 1 1/2"	3" - 1 1/2"	2" 1/2 - 2"	2"	3"
36" - 8"	36" - 4"	5" - 3"	3" 1/2 - 3"	4" - 3" 1/2"	
		36" - 6"	5" - 4"	6" - 5"	
			12" - 6"	12" - 8"	
			36" - 14"	36" - 14"	

Diamètre collecteur Run size	CLASSE - RATING 150 - 300 - 600 - 1500 - Sch. 160 - XXS				
	1/2"	3/4"	1"	1 1/2"	2"
	3" - 1 1/2"	4" - 1 1/2"	4" - 1 1/2"	4" - 2"	4" - 3"
36" - 4"	36" - 6"	36" - 6"	36" - 6"	8" - 5"	
				36" - 10"	

SIZES in mm - DIMENSIONS en mm.

Other Dimensions of Flanges according to ASME B16.5 - Dimensions des brides selon ASME B16.5 RF or RTJ

flange facings to be precised. Brides RF ou RTJ à préciser.

Flanged weld-outlets suivant - acc.to API 6A - Type 6B & 6BX sur demande - on request (5 000 psi / 10 000 psi / 15 000 psi)



### LATRO FLANGED OUTLET

Flange per B 16.5  
 BW per B16.25  
 Size: 1/2"to 2"  
 Other sizes on request



### ELBO FLANGED OUTLET

Flange per B 16.5  
 BW per B16.25  
 Size: 1/2"to 2"

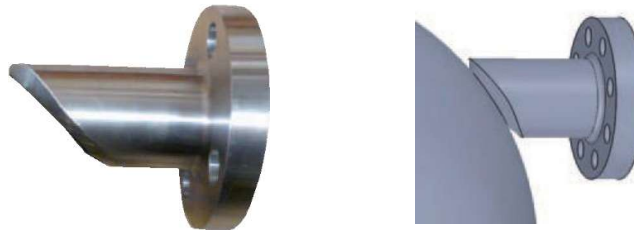

### SWEEPO FLANGED OUTLET

Flange per B 16.5  
 BW per B16.25  
 Size: 1/2"to 2"

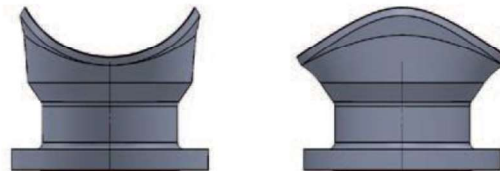

BRANCH OUTLETS  
(P.23 - P.42)



## I. HIGH PRESSURE DIVISION DIVISION HAUTEPRESSION

### 3. SPECIAL FORGED PIECES & BUTTWELD FITTINGS ASME B 16.9 (subsea & specific applications) *Pièces spéciales de forge*

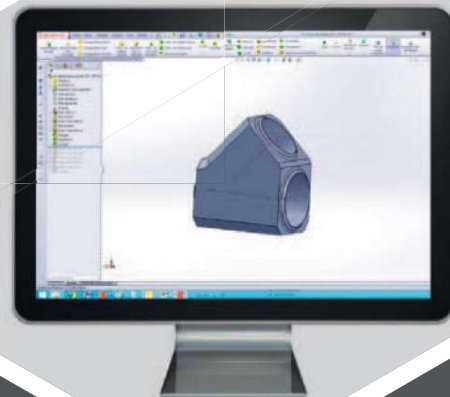
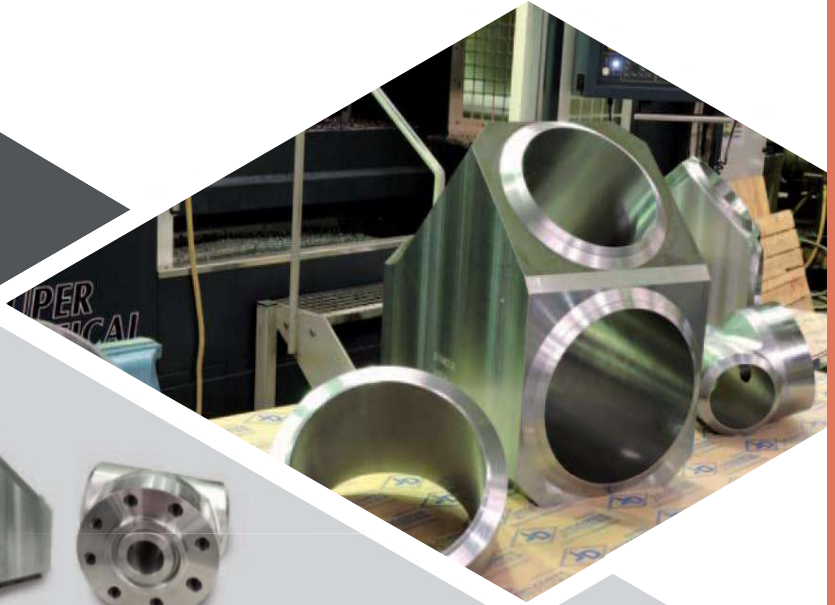

<b>WYE PIECE .....</b>	<b>45</b>
<b>TARGET TEE .....</b>	<b>45</b>
<b>BARRED TEE .....</b>	<b>45</b>
<b>FLANGED TEE .....</b>	<b>46</b>
<b>LATERAL TEE .....</b>	<b>46</b>
<b>BW TEE .....</b>	<b>46</b>



**WYE PIECE**

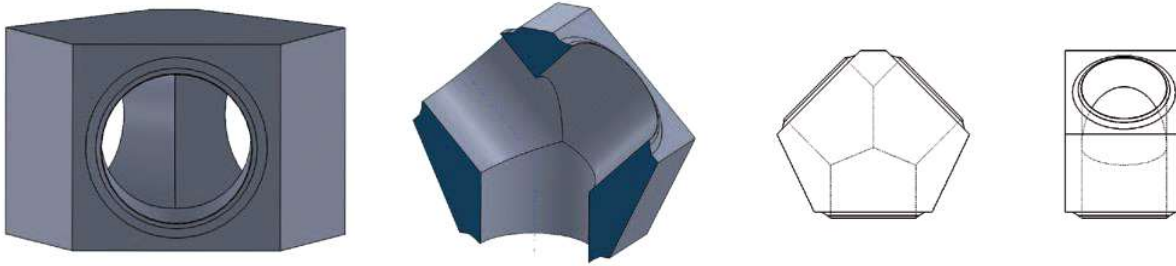

From ½ "up to 48" other sizes on request Schedule:  
SCH20, SCH30, SCH40, STD, SCH80, XS, SCH60, SCH80, SCH120, SCH140, SCH160, XXS

**TARGET TEE**

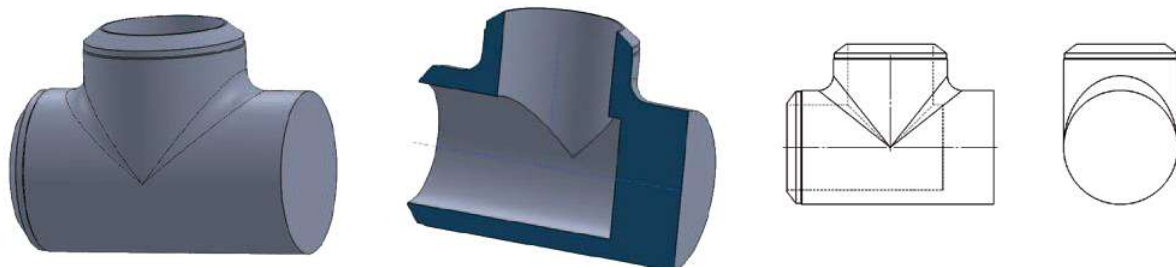

From ½ "up to 48" other sizes on request Schedule:  
SCH20, SCH30, SCH40, STD, SCH80, XS, SCH60, SCH80, SCH120, SCH140, SCH160, XXS

**BARRED TEE**

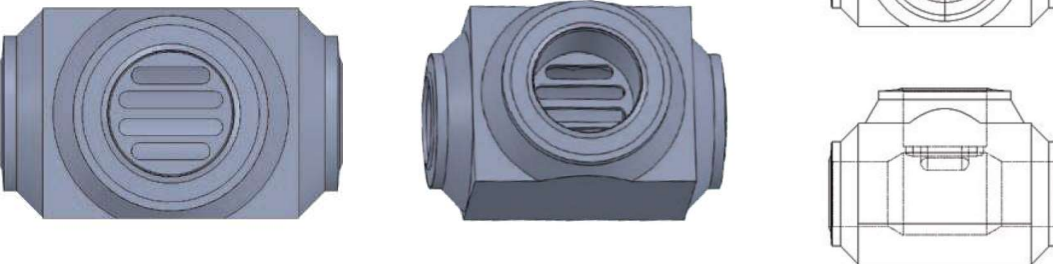

From ½ "up to 48" other sizes on request Schedule:  
SCH20, SCH30, SCH40, STD, SCH80, XS, SCH60, SCH80, SCH120, SCH140, SCH160, XXS

### FLANGED TEE

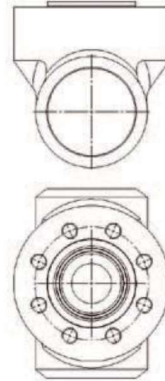
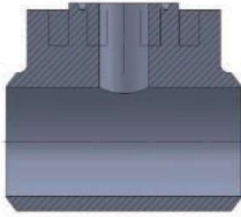

From ½ "up to 48" other sizes on request Schedule:  
SCH20, SCH30, SCH40, STD, SCH80, XS, SCH60, SCH80, SCH120, SCH140, SCH160, XXS

### LATERAL TEE

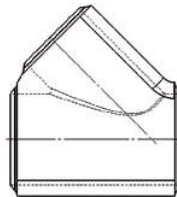
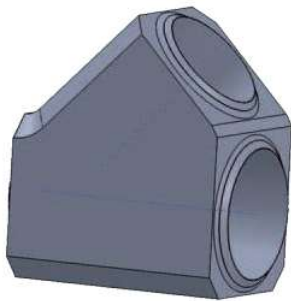

From ½ "up to 48" other sizes on request Schedule:  
SCH20, SCH30, SCH40, STD, SCH80, XS, SCH60, SCH80, SCH120, SCH140, SCH160, XXS

### BW TEE

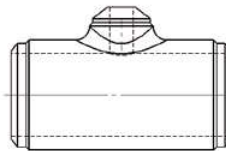
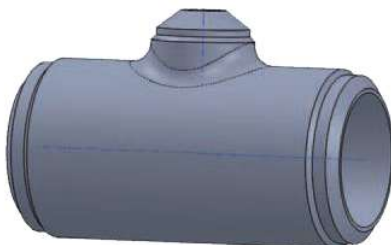

From solid forgings acc.to ASME B16.9

## II. API COUPLINGS DIVISION

### DIVISION MANCHONS PETROLIERS

**API 5CT casing and tubing couplings**

*Manchons tubing & casing API 5CT*

**API 5L line pipe couplings**

*Manchons line pipe API 5L*



**CASING COUPLING API 5CT - 2011 (BTC-LTC-STC)..... 49**

**TUBING COUPLING API 5CT - 2011 (EUE & NU) ..... 50**

**MARKING CASING - TUBING - MARQUAGE TUBE DE CUVELAGE - TUBE DE PRODUCTION ..... 51**

**API 5L - 2007 - LINE PIPE COUPLING ..... 52**





## CASING COUPLING API 5CT - 2011 (BTC-LTC-STC)

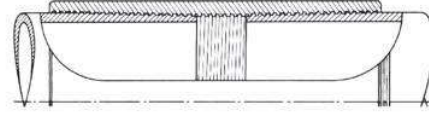
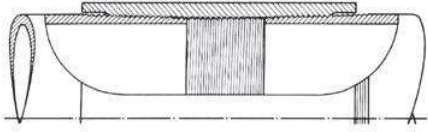

### Casing pipe

#### Connections

- API round thread

The pipe is threaded at both end to have a thread pin ; the pipes are joined together by means of a coupling. To API specifications short or long threads with corresponding couplings are available. Long thread casing can transmit higher axial loads than short thread casing.

- API buttress

The connecting system is identical. Instead of the «round thread», there is a «buttress» type thread which allows the transmission of very high axial loads.

### Tube de cuvelage

#### Raccordements

- Api round thread

Le tube est fileté aux deux extrémités ; les tubes sont raccordés entre eux au moyen d'un manchon. Selon les spécifications API, il existe deux types de filetage avec les manchons correspondants : court ou long. Les tubes de Cuvelage avec filetage long peuvent transmettre des charges axiales supérieures à celles transmises par les tubes avec un filetage court.

- API buttress

Le principe de raccordement est identique à celui du « round thread » - . Au lieu du filetage « round thread », il y a un filetage type « buttress » qui autorise la transmission de très fortes charges axiales.

BUTTRESS THREAD CASING COUPLING DIMENSIONS (mm), WEIGHT (Kg) ALL GROUPS\*  
JD 470

Size Designation	Outside Diameter		Length Minimum	Diameter of Counter bore	Width of Bearing Face	Weight (Kg)	
	Regular	Special Clearance				Regular	Special Clearance
4 1/2"	127.00	123.82	225.42	117.86	3.18	4.55	3.48
5"	141.30	136.52	231.78	130.56	3.97	5.85	4.00
5 1/2"	153.67	149.22	235.95	143.26	3.97	6.36	4.47
6 5/8"	187.71	177.80	244.48	171.83	6.35	11.01	5.65
7"	200.03	187.32	254.00	181.36	5.56	10.54	6.28
7 5/8"	215.90	206.38	236.52	197.23	7.94	15.82	9.29
8 5/8"	244.48	231.78	269.88	222.63	9.52	20.86	10.80
9 5/8"	269.88	257.18	269.88	248.03	9.52	23.16	12.02
10 3/4"	298.45	285.75	269.88	276.61	9.52	25.74	13.39
11 3/4"	323.85	-	269.88	302.01	9.52	28.03	-
13 3/8"	365.12	-	269.88	343.28	9.52	31.77	-
16"	431.80	-	269.88	410.31	9.52	40.28	-
18 5/8"	508.00	-	269.88	476.99	9.52	62.68	-
20"	533.40	-	269.88	511.91	9.52	50.10	-

ROUND THREAD CASING COUPLING DIMENSIONS (mm), WEIGHT (Kg) ALL GROUPS\*

Size Designation	Outside Diameter	Length, Minimum		Diameter of Recess	Width of Bearing Face	Weight (Kg)	
		Short JD 450	Long JD 460			Short JD 450	Long JD 460
4 1/2"	127.00	158.75	177.80	116.68	3.97	3.62	4.15
5"	141.30	165.10	196.85	129.38	4.76	4.66	5.75
5 1/2"	153.67	171.45	203.20	142.08	3.18	5.23	6.42
6 5/8"	187.71	184.15	222.25	170.66	6.35	9.12	11.34
7"	200.03	184.15	228.60	180.18	4.76	8.39	10.83
7 5/8"	215.90	190.50	234.95	197.64	5.56	12.30	15.63
8 5/8"	244.48	196.85	254.00	223.04	6.35	16.23	21.67
9 5/8"	269.88	196.85	266.70	248.44	6.35	18.03	25.45
10 3/4"	298.45	203.20	-	277.02	6.35	20.78	-
11 3/4"	323.85	203.20	-	302.42	6.35	22.64	-
13 3/8"	365.12	203.20	-	343.69	5.56	25.66	-
16"	431.80	228.60	-	411.96	5.56	34.91	-
18 5/8"	508.00	228.60	-	478.63	5.56	54.01	-
20"	533.40	228.60	292.10	513.56	5.56	43.42	57.04

## TUBING COUPLING API 5CT (EUE & NU)

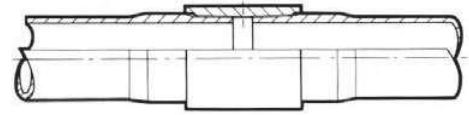
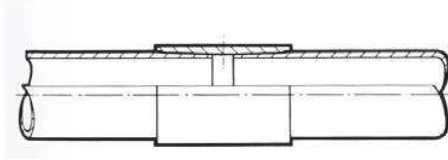

### CONNECTIONS

#### TUBING PIPE

coupling joint

API tubing threaded and coupled is externally threaded on both ends of a non upset or upset pipe. Single lengths are joined by an internally threaded coupling. Coupling O.D. can be regular or special clearance (reduced O.D.). Tubing thread is API round thread.

Nota: special bevel coupling can be furnished for non upset and upset tubing when specified on purchase order.

### RACCORDEMENTS

#### TUBE DE PRODUCTION

Raccord manchonné

Le tube de production API fileté manchonné est fileté des deux côtés d'un tube à extrémités non repoussées ou repoussées. Les longueurs unitaires sont raccordées par un manchon taraudé. Le diamètre extérieur du manchon peut être «régulier» ou «spécial clearance» (dia. ext. réduit). Le filetage des tubes de production est de type API round thread.

Nota : des manchons à chanfrein spécial peuvent être fournis pour les tubes à extrémités non repoussées ou repoussées sur spécification particulière lors de la commande.

UPSET TUBING COUPLING DIMENSIONS (mm), WEIGHT (Kg) GROUPS\* 1,2 and 3

Group*	Size Designation	Outside diameter			Length Minimum	Diameter Of Recess	Width of Bearing Face, Regular	Maximum Bearing Face Diameter		Weight (Kg)	
		Regular JD 430	Special Bevel JD 429	Special Clearance JD 424				Special Bevel JD 429	Special Clearance JD 424	Regular JD 430	Special Clearance JD 424
1,2	1.050	42.16	42.16	-	82.55	35.00	2.38	37.80	-	0.38	-
1,2	1.315	48.26	48.26	-	88.90	38.89	2.38	42.77	-	0.57	-
1,2	1.660	55.88	55.88	-	95.25	47.63	3.18	50.95	-	0.68	-
1,2	1.900	63.50	63.50	-	98.42	54.76	3.18	58.34	-	0.84	-
1,2,3	2 3/8"	77.80	77.80	73.91	123.82	67.46	3.97	71.83	69.90	1.55	1.07
1,2,3	2 7/8"	93.17	93.17	87.88	133.35	80.16	5.56	85.88	83.24	2.40	1.55
1,2,3	3 1/2"	114.30	114.30	106.17	146.05	96.85	6.35	104.78	100.71	4.10	2.38
1,2	4"	127.00	127.00	-	152.40	109.55	6.35	117.48	-	4.82	-
1,2	4 1/2"	141.30	141.30	-	158.75	122.25	6.35	130.96	-	6.05	-

NON-UPSET TUBING COUPLING DIMENSIONS (mm), WEIGHT (Kg) GROUPS\* 1,2 and 3  
JD 420

Group*	Size Designation	Outside Diameter	Length Minimum	Diameter of Recess	Width of Bearing Face	Bearing Face Diameter maximum Special Bevel	Weight (Kg)
1,2	1.050	33.35	80.96	28.27	1.59	30.00	0.23
1,2	1.315	42.16	82.55	35.00	2.38	37.80	0.38
1,2	1.660	52.17	88.90	43.76	3.18	47.17	0.59
1,2	1.900	55.88	95.25	49.86	1.59	52.07	0.56
1,2,3	2 3/8"	73.02	107.95	61.93	4.76	66.68	1.28
1,2,3	2 7/8"	88.90	130.18	74.63	4.76	80.98	2.34
1,2,3	3 1/2"	107.95	142.88	90.50	4.76	98.42	3.71
1,2	4"	120.65	146.05	103.20	4.76	111.12	4.35
1,2	4 1/2"	132.08	155.58	115.90	4.76	123.19	4.89

## MARKING CASING - TUBING

### Marquage tube de cuvelage - tube de production

GRADE MARKING / MARQUAGE NUANCE ACIER	
Steel Grade / Nuance Acier	Marking / Marquage
H 40	H
J 55	J
K 55	K
N 80 type 1	N1
N 80 type Q	NQ
P 110	P
L 80 type 1	L
L 80 type 9 Cr	L 9 CR
L 80 type 13 Cr	L 13 CR
C 90 type 1	C 90 - 1
C 90 type 2	C 90 - 2
C 95	C
T 95 type 1	T 95 - 1
T 95 type 2	T 95 - 2
Q 125 type 1	Q1
Q 125 type 2	Q2
Q 125 type 3	Q3
Q 125 type 4	Q4
N 80 type Q	NQ

TYPE OF THREAD / TYPE DE FILETAGE	
Casing / Tube de Cuvelage	SYMBOL
Round Thread	CSG
Long Round Thread	LCSG
Buttress Thread	BCSG
Tubing / Tube de Production	
Non upset	TBG
External upset	UPTBG

COLOR IDENTIFICATION / IDENTIFICATION COULEUR		
Nuance Acier Steel Grade	PIPE / TUBE	COUPLING / MANCHON
H 40	No marking or black / Pas de marquage ou noir	Same as for pipe / Idem tube
J 55 Tubing	One bright green band / Une bande vert clair	Bright green / Vert clair
J 55 Casing	One bright green band / Une bande vert clair	Bright green + white band / Vert clair + bande blanche
K 55	Two bright green bands / Deux bandes vert clair	Bright green / Vert clair
N 80 type 1	One red band / Une bande rouge	Red / Rouge
N 80 type Q	Red and one green band / Rouge et une bande verte	Red + 1 green band / Rouge + 1 bande verte
P 110	White / Blanc	White / Blanc
Q 125 type 1	Orange / Orange	Orange / Orange
Q 125 type 2	One orange and one yellow band / Une bande orange et une jaune	Orange and one yellow band / Orange avec une bande jaune
Q 125 type 3	One orange and one green band / Une bande orange et une vert	Orange and one green band / Orange avec une bande verte
Q 125 type 4	One orange, and one brown band / Une bande orange et une marron	Orange and one brown band / Orange avec une bande marron
L 80 type 1	One red and one brown band / Une bande rouge et une marron	Red with brown band / Rouge avec une bande marron
L 80 - 9 Cr	One red, one brown, and two yellow bands / Une bande rouge, une marron, deux jaunes / One red, one brown, and two yellow bands	Red with two yellow bands / Rouge avec deux bandes jaunes
L 80 - 13 Cr	One red and one brown and one yellow band / Une bande rouge, une marron, une jaune / One red and one brown and one yellow band	Red with one yellow band / Rouge avec une bande jaune
C 90 type 1	One purple band / One purple band	Purple / Violet
C 90 type 2	One purple and one yellow band / Une bande violette et une jaune	Purple and one yellow band / Violet avec une bande jaune
C 95	One brown band / Une bande marron	Brown / Marron
T 95 type 1	One silver band / Une bande argent	Silver / Argent
T 95 type 2	One silver and one yellow band / Une bande argent et une bande jaune	Silver and one yellow band / Argent avec une bande jaune

GROUP 1	
Grade	Type
H40	-
J55	-
K55	-
N80	1
N80	Q

GROUP 2	
Grade	Type
L80	1
L80	9Cr
L80	13Cr
C90	1
C90	2
C95	-
T95	1
T95	2

GROUP 3	
Grade	Type
P110	

GROUP 4	
Grade	Type
Q125	1
Q125	2
Q125	3
Q125	4

## API 5L - LINE PIPE COUPLING

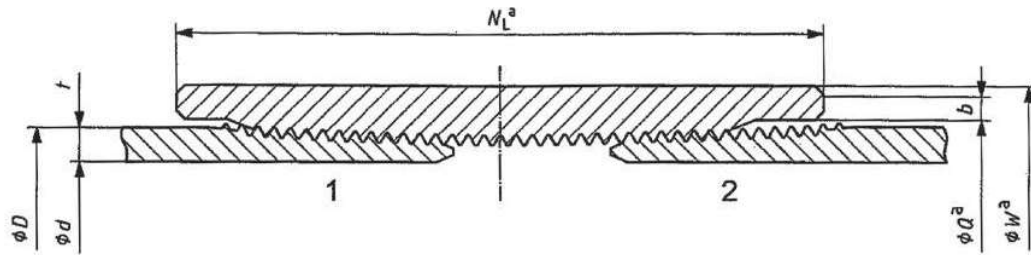

- |    |  |   |                                    |
|----|--|---|------------------------------------|
| 1  | basic power-tight make-up              | b | specified width of bearing face    |
| 2  | hand-tight make-up                     | D | specified outside diameter of pipe |
| NL | specified minimum length               | t | wall thickness of pipe             |
| W  | specified outside diameter of coupling | d | inside diameter pipe               |
| Q  | specified diameter of recess           |   |                                    |

API COUPLINGS DIVISION  
(P.47 - P.52)

Coupling dimensions, masses and tolerances / Dimensions des manchons, poids et tolérances											
OD (ex designation)	Specified Outside diameter of pipe D		Specified outside diameter a Wb		Specified Minimum Length NLb		Specified diameter of recess Qb		Specified width of bearing face b		coupling weight kg
	inch	mm	inch	mm	inch	mm	inch	mm	inch	mm	
1/8"	0.405	10,3	0.563	14,3	1.063	27	0.468	11,9	0.031	0,8	0,02
1/4"	0.54	13,7	0.719	18,3	1.625	41,3	0.603	15,3	0.031	0,8	0,04
3/8"	0.675	17,1	0.875	22,2	1.625	41,3	0.738	18,3	0.031	0,8	0,06
1/2"	0.84	21,3	1.063	27	2.125	54	0.903	22,9	0.063	1,6	0,11
3/4"	1.05	26,7	1.313	33,4	2.125	54	1.113	28,3	0.063	1,6	0,15
1"	1.315	33,4	1.576	40	2.625	66,7	1.378	35	0.093	2,4	0,25
1 1/4"	1.66	42,2	2.054	52,2	2.750	69,8	1.723	43,8	0.093	2,4	0,47
1 1/2"	1.9	48,3	2.200	55,9	2.750	69,8	1.963	49,9	0.093	2,4	0,41
2 3/8"	2.375	60,3	2.875	73	2.875	73	2.469	62,7	0.125	3,2	0,84
2 7/8"	2.875	73	3.375	85,7	4.125	104,8	2.969	75,4	0.188	4,8	1,48
3 1/2"	3.5	88,9	4.000	101,6	4.250	108	3.594	91,3	0.188	4,8	1,86
4"	4.00	101,6	4.625	117,5	4.375	111,1	4.094	104	0.188	4,8	2,69
4 1/2"	4.500	114,3	5.200	132,1	4.500	114,3	4.594	116,7	0.250	6,4	3,45
5 9/16"	5.563	141,3	6.296	159,9	4.625	117,5	5.657	143,7	0.250	6,4	4,53
6 5/8"	6.625	168,3	7.390	187,7	4.875	123,8	6.719	170,7	0.250	6,4	5,87
8 5/8"	8.625	219,1	9.625	244,5	5.250	133,4	8.719	221,5	0.250	6,4	10,52
10 3/4"	10.750	273,1	11.750	298,4	5.750	146	10.844	275,4	0.375	9,5	14,32
12 3/4"	12.750	323,9	14.000	355,6	6.125	155,6	12.844	326,2	0.375	9,5	22,37
14"	14.000	355,6	15.000	381	6.375	161,9	14.094	358	0.375	9,5	20,81
16"	16.000	406,4	17.000	431,8	6.750	171,4	16.094	408,8	0.375	9,5	23,35
18"	18.000	457	19.000	482,6	7.125	181	18.094	459,6	0.375	9,5	30,2
20"	20.000	508	21.000	533,4	7.625	193,7	20.094	510,4	0.375	9,5	36,06

a Tolerances for outside diameter of couplings are +/- 0,01W

b These symbols have been retained on the basis of their long-standing use by API Spec 5L and API Spec 5CT in spite of the fact that they are not in accordance with the ISO system of symbols

### **III. LOW PRESSURE DIVISION**

#### ***DIVISION BASSE PRESSION***

**Wrought steel threaded fittings EN 10241**

*Raccords acier gaz suivant EN 10241*

**Pipe nipples and tubulars**

*Mamelons en acier et pièces tubulaires*

**Steel couplings/sockets and fittings for fire fighting installations**

*Manchons en acier et raccords pour installations anti-feu*



<b>WROUGHT STEEL FITTINGS - RACCORDS GAZ</b> .....	<b>55-56</b>
<b>PIPE NIPPLES AND TUBULARS - MAMELONS EN ACIER &amp; PIÈCES TUBULAIRES</b> .....	<b>57</b>
<b>STEEL COUPLINGS - MANCHONS EN ACIER</b> .....	<b>58</b>
<b>STEEL MERCHANT COUPLINGS - MANCHONS EN ACIER TYPE AMÉRICAIN</b> .....	<b>59</b>
<b>SOCKETS AS PER NFA 49192 - MANCHONS SUIVANT NFA 49192</b> .....	<b>59</b>
<b>SPECIAL LENGTHS SOCKETS AND SPECIAL SOCKETS</b> <i>MANCHONS LONGUEURS SPÉCIALES ET MANCHONS SPÉCIAUX</i> .....	<b>59</b>
<b>RIGID CONDUIT COUPLINGS - MANCHONS CONDUITES ÉLECTRIQUES</b> .....	<b>60</b>
<b>CONDUIT COUPLINGS FOR ELECTRICAL WIRING - MANCHONS CONDUITES ÉLECTRIQUES</b> .....	<b>60</b>
<b>PROFILE SOCKETS FOR SPRINKLER SYSTEMS - MANCHONS GRUGÉS POUR INSTALLATIONS ANTI-FEU</b> .....	<b>61</b>
<b>PROFILE TUBULAR GROVED OR THREADED - BOBINES GRUGÉES RAINURÉES OU FILETÉES</b> .....	<b>61</b>



## WROUGHT STEEL FITTINGS

### Raccords gaz

Dimensions according to EN 10241  
 Threads / filetages EN10226 / BS21 / ISO7.1 / ISO 228  
 NF03.004 / NF03.005  
 DIN 2999 / DIN259

Finishing / finition  
 Black / noir  
 Hot dip galvanising / galvanisation à chaud  
 Electro plating / galvanisation électrolytique







NOMINAL DIAMETER IN INCH		1/8"	1/4"	3/8"	1/2"	3/4"	1"	1 1/4"	1 1/2"	2"	2 1/2"	3"	4"	5"	6"	
NOMINAL DIAMETER IN MM		6	8	10	15	20	25	32	40	50	65	80	100	125	150	
	90° ELBOW COUDE 90° JD 190	Centre to face	16	22	24	32	35	43	51	52	64	76	89	115	140	160
	EQUAL TEE TÉ ÉGAL JD 200	Centre to face	16	22	24	32	35	43	51	52	64	76	89	115	140	160
	CROSS CROIX JD 220	Centre to face	16	22	24	32	35	43	51	52	64	76	89	115	140	160
	45° ELBOW COUDE 45° JD 194	Centre to face	X	X	19	22	27	33	38	44	51	59	66	77	89	92
	STREET ELBOW COUDE MF JD 195	Centre to face female	X	19	21	25	30	37	43	49	59	68	81	100	X	X
		Centre to face male	X	27	29	35	40	46	54	57	70	83	94	115	X	X
	REDUCED TEE TÉ RÉDUIT JD 202		X	TOUTES RÉDUCTIONS JUSQUE 6" ALL REDUCTIONS ARE AVAILABLE UP TO 6"												
	REDUCING SOCKET MANCHON RÉDUIT JD 125		X	TOUTES RÉDUCTIONS JUSQUE 6" ALL REDUCTIONS ARE AVAILABLE UP TO 6"												
	CAP BOUCHON FEMELLE JD 188	Length	19	24	27	37	38	44	51	54	60	67	73	86	98	98
		Minimum thickness	3,5	3,5	3,5	4	4	4,5	5	5,5	6	6	7	7	7,5	8,5

## WROUGHT STEEL FITTINGS

### Raccords gaz

Dimensions according to EN 10241  
 Threads / filetages EN10226 / BS21 / ISO7.1 / ISO 228  
 NF03.004 / NF03.005  
 DIN 2999 / DIN259

Finishing / finition  
 Black / noir  
 Hot dip galvanising / galvanisation à chaud  
 Electro plating / galvanisation électrolytique  
 Zinc flake / dachromate

NOMINAL DIAMETER IN INCH			1/8"	1/4"	3/8"	1/2"	3/4"	1"	1 1/4"	1 1/2"	2"	2 1/2"	3"	4"	5"	6"
NOMINAL DIAMETER IN MM			6	8	10	15	20	25	32	40	50	65	80	100	125	150
	HEXAGONAL NIPPLE MAMELON HEXAGONAL JD 161	Min length of thread	9,5	12,5	12,5	17,5	19	21	24	24	27	32	35	40	45	45
		Width across flats of hexagon	12	14	17	22	27	36	46	50	65	78	90	115	140	166
	HEXAGONAL BUSHING RÉDUCTION MÂLE-FEMELLE JD 177	Overall length	X	18,5	20,5	25,5	29	31	35	37	41	48	54	62	70	70
		Width across flats of hexagon	X	14	17	22	27	36	46	50	65	78	90	115	140	166
	SQUARE HEAD PLUG BOUCHON MÂLE TÊTE CARRÉE JD 181	Minimum length of thread	6,5	9,7	10,1	13,2	14,5	16,8	19,1	19,1	23,4	26,7	29,8	35,8	40,1	40,1
		Size of square	6	9	11	13	14	17	22	27	32	37	37	46	51	60
		Minimum height of square	6	6	10	10	12	12	16	16	19	19	22	25	29	32
	FLAT & CONICAL SEAT UNION RACCORD UNION JOINTS PLAT ET CONIQUE JD 209-208	Overall length	37	40	46	51	57	64	70	79	89	102	107	118	X	X
		Length of nut	15	15	16	18	20	22	24	25	27	30	31	34	X	X
MF Union also available / union MF disponible - ref JD 211																
	HEXAGONAL HEAD PLUG BOUCHON MÂLE TÊTE HEXAGONALE JD 187	Minimum length of thread	9,5	12,5	12,5	17,5	19	21	24	24	27	32	35	40	X	X
		Size of hexagon	12	14	17	22	27	36	46	50	65	78	90	115	X	X
		Minimum height of hexagon	6	6	8	8	10	10	11	13	14	16	19	22	X	X
	HEXAGONAL BACKNUT ÉCROU HEXAGONAL JD 132	Width across flats	17	19	24	30	36	41	50	60	70	90	100	130	160	190
		Length of nut	6,5	6,5	7	8	9	9,5	11	12	13	17	21	22	24	25
	WELDING UNION BUTT/BUTT RACCORD UNION BUTTWELDING JD 230	Length	X	On request	On request	44	54	65	66	67	67	X	X	X	X	X
		Hex. diameter	X			32	41	50	55	60	60	X	X	X	X	X
		OD in mm	X			21,3	26,9	33,7	42,4	48,3	60,3	X	X	X	X	X
	WELDING UNION BUTT/MALE RACCORD UNION BUTTWELDING - MÂLE FILETÉ DIN 2999 JD 229	Length	X	On request	On request	61	71	81	89	99	105	X	X	X	X	X
		Hex. diameter	X			32	41	50	60	70	85	X	X	X	X	X
		OD in mm	X			21,3	26,9	33,7	42,4	48,3	60,3	X	X	X	X	X

Base materials: forgings/seamless pipes/round and hexagonal bars

Matières de base : ébauches forgées / tubes sans soudure / barres rondes et hexagonales







## PIPE NIPPLES AND TUBULARS

### Mamelons en acier & pièces tubulaires

Dimensions according to / suivant EN 10241  
 Threads / filetages EN10226 / BS21 / ISO7.1 / ISO 228  
 NF03.004 / NF03.005  
 DIN 2999/DIN259

Finishing / finition  
 Black / noir  
 Hot dip galvanising / galvanisation à chaud

NOMINAL DIAMETER IN INCH		1/8"	1/4"	3/8"	1/2"	3/4"	1"	1 1/4"	1 1/2"	2"	2 1/2"	3"	4"	5"	6"
NOMINAL DIAMETER IN MM		6	8	10	15	20	25	32	40	50	65	80	100	125	150
	RUNNING NIPPLE MAMELON CYLINDRIQUE JD 153	Length in mm	x	19	21	27	30	33	38	38	48	51	57	70	78
	CLOSE NIPPLE MAMELON COURT JD 151	Length in mm	x	27	28	37	39	46	51	51	60	69	75	87	96
	BARREL NIPPLE MAMELON TUBE JD 150	Length in mm	x	38	38	51	54	60	70	70	79	89	102	114	124
	90° BEND COURBE 90° JD F90	Centre to face	x	64	73	86	102	121	146	165	203	248	292	381	540
	45° BEND COURBE 45° JD F45	Centre to face	x	57	64	76	89	105	127	143	175	213	248	324	457



BARREL NIPPLES  
BOBINE FILETÉE  
JD 150



BOUT À SOUDER  
HALF-NIPPLE  
JD 152

Ø/mm	1/8"	1/4"	3/8"	1/2"	3/4"	1"	1 1/4"	1 1/2"	2"	2 1/2"	3"	4"
30	ab	ab	ab	ab	ab	ab						
40	ab	ab	ab	ab	ab	ab	ab	ab	ab			
50	abc	abc	abc	abc	abc	abc	abc	abc	abc			
60	ab	ab	ab	ab	ab	ab	ab	ab	ab	ab	ab	
80	ab	ab	ab	ab	ab	ab	ab	ab	ab	ab	ab	ab
100	abc	abc	abc	abc	abc	abc	abc	abc	abc	abc	abc	abc
120	ab	ab	ab	ab	ab	ab	ab	ab	ab	ab	ab	ab
150	abc	abc	abc	abc	abc	abc	abc	abc	abc	abc	abc	abc
180	a	a	a	a	a	a	a	a	a	a	a	a
200	abc	abc	abc	abc	abc	abc	abc	abc	abc	abc	abc	abc
250	a	a	a	a	a	a	a	a	a	a	a	a
300	a	a	a	a	a	a	a	a	a	a	a	a

a : barrel nipples welded tube  
(black or galvanized)

b : half nipples welded tube (black or  
galvanized)

c : seamless pipe standard  
lengths-other on request

a.b.c: Any other lengths available on request



LONGSCREWS  
LONGUE VIS  
JD 154

NOMINAL SIZE IN MM	NOMINAL SIZE IN INCH	MIN. USEFUL LENGTH OF THE THREAD IN MM	OVERALL LENGTH IN MM
8	1/4"	37	80
10	3/8"	40	100
15	1/2"	52	100
20	3/4"	54	120
25	1"	62	140
32	1 1/4"	70	150
40	1 1/2"	71	150
50	2"	82	170
65	2 1/2"	97	180
80	3"	106	200
100	4"	121	250
125	5"	130	on request
150	6"	132	on request

Base materials: medium and heavy series welded pipes / seamless pipes

Matières de base : tubes soudés séries moyenne et forte / tubes sans soudure

## STEEL COUPLINGS

### Manchons en acier

Dimensions according to/suivant EN 10241  
 Threads / filetages EN10226 / BS21 / ISO7.1 / ISO 228  
 NF03.004 / NF03.005  
 DIN 2999 / DIN259

Finishing / finition  
 Black / noir  
 Degreased / dégraissé  
 Hot dip galvanising / galvanisation à chaud  
 Electro plating / galvanisation électrolytique

NOMINAL DIAMETER IN INCH			1/8"	1/4"	3/8"	1/2"	3/4"	1"	1 1/4"	1 1/2"	2"	2 1/2"	3"	3 1/2"	4"	5"	6"
NOMINAL DIAMETER IN MM			6	8	10	15	20	25	32	40	50	65	80	90	100	125	150
	SOCKETS MEDIUM TYPE JD 101 EN 10241	Min OD	15	18,5	21,3	26,6	31,8	39,5	48,3	54,5	66,2	82	95	On request	121,4	146,3	173,3
		Length	17	25	26	34	36	43	48	48	56	65	71		83	92	92
	HALF SOCKETS MEDIUM TYPE JD 140 EN 10241	Min OD	15	18,5	21,3	26,6	31,8	39,5	48,3	54,5	68	84,2	98,4	On request	124	149	177
		Length	8	11	12	15	17	20	22	22	26	30	34		40	44	44
G40 1" (OD 39,5 - L 20) - G40 1 1/2" (OD 54,5 - L 25) - ALSO AVAILABLE																	
	SOCKETS HEAVY TYPE JD 102 EN 10241	Min OD	15	18,5	22	27	32,5	39,5	49	56	68	84	98	On request	124	151	177
		Length	19	27	28	37	39	46	51	51	60	69	75		87	96	96
	HALF SOCKETS HEAVY TYPE JD 141 EN 10241	Min OD	15	18,5	22	27	32,5	39,5	49	56	68	84	98	On request	124	151	177
		Length	8	11	12	16	19	21	25	25	28	30	35		40	44	44
G41 3/4" (OD 33,3 - L 17) - G41 1 1/4" (OD 49 - L 22) - G41 2" (OD 69,5 - L 28) - ALSO AVAILABLE																	
	HEAVY COUPLING JD 105 DIN 2999 DIN 2986-1959	Diameter in mm	X	X	X	X	33,1	X	49	56	69,1	81	98	On request	123,4	151,3	176,5
		Length in mm	X	X	X	X	36	X	48	48	56	65	71		83	92	92
	SEAMLESS COUPLING JD 127 P235 GH TC1 DIN 2999 ST 35.8/1 DIN 17175 P235GH TC1	Diameter in mm	15	18,5	21,3	26,9	33,7	42,4	51	57	70	88,9	101,6	X	132	X	X
		Length in mm	17	25	26	34	36	43	48	48	56	65	71	X	83		
	SEAMLESS HALF COUPLING JD 147 DIN 2999 ST 35.8/1 DIN 17175	Diameter in mm	15	18,5	21,3	26,9	33,7	42,4	51	57	70	88,9	101,6	X	132	On request	On request
		Length in mm	8	11	12	15	17	20	22	22	26	30	35	X	40		

Base materials: special Delcorte socket tubing / seamless pipes



Matières de base : tubes à manchons suivant spécification Delcorte / tubes sans soudure

## STEEL MERCHANT COUPLINGS

### Manchons en acier type américain

Dimensions according to/suivant ASTM A 865  
Threads / filetages ANSI B 1.20.1

Finishing / finition  
Black / noir  
Hot dip galvanising / galvanisation à chaud

NOMINAL DIAMETER IN INCH		1/8"	1/4"	3/8"	1/2"	3/4"	1"	1 1/4"	1 1/2"	2"	2 1/2"	3"	3 1/2"	4"	5"	6"	
NOMINAL DIAMETER IN MM		6	8	10	15	20	25	32	40	50	65	80	90	100	125	150	
	MERCHANT COUPLING JD 112	Diameter in mm	14,3	18,3	22,23	27	33,3	40	48,26	55,88	69,85	82,55	101,6	On request	127	159,9	187,7
	ANSI B1.20.1	Length in mm	19,1	28,6	28,6	38,1	39,7	49,2	50,8	50,8	52,38	77,78	80,96		87,3	93,66	100
	HALF COUPLING JD 144	Diameter in mm	14,3	18,3	22,23	27	33,3	40	48,26	55,88	69,85	82,55	101,6	On request	127	On request	On request
	ANSI B1.20.1	Length in mm	8,73	13,49	13,49	18,25	19,05	23,81	24,6	24,6	25,4	39	41		44		

Base materials: special Delcorte socket tubing / seamless pipes  
Matières de base : tubes à manchons suivant spécification Delcorte / tubes sans soudure

## SOCKETS AS PER NFA 49192

### Manchons suivant NFA 49192

Outside diameter in inch / diamètre extérieur (pouces)		1/4"	3/8"	1/2"	3/4"	1"	1 1/4"	1 1/2"	2"
Nominal diameter / diamètre nominal		8	10	15	20	25	32	40	50
Mini O.D. in mm / diamètre ext. mini en mm		18,5	21,5	26,8	33,5	39,5	50	56	69
	Full couplings / Manchons entiers Length mm / longueur	25	26	34	36	43	48	48	56
	Half couplings / demi manchons Length mm / longueur	10	12	15	17	20	25	25	28
	Half couplings with shoulder / bagues épaulées Length mm / longueur	10	11	12	13	16	20	24	30

## SPECIAL LENGTHS SOCKETS AND SPECIAL SOCKETS

### Manchons longueurs spéciales et manchons spéciaux

Raw material / matière de base	Welded or seamless / tubes soudés ou sans soudure à la demande
Sizes / dimensions	from/de 1/8" to/à 8" including/avec 2 1/4" - 3 1/2"...
Lengths / longueurs	Up to 250 mm - above on request / jusque 250mm au-delà sur demande
Threads / filetages	at customer's option / à la demande
Drawing and tolerances / plan et tolérances	supplied by the customer or designed internally / fournis par le client ou établis par nos soins

Examples of sockets as per customer's drawings / exemples de manchons sur plans

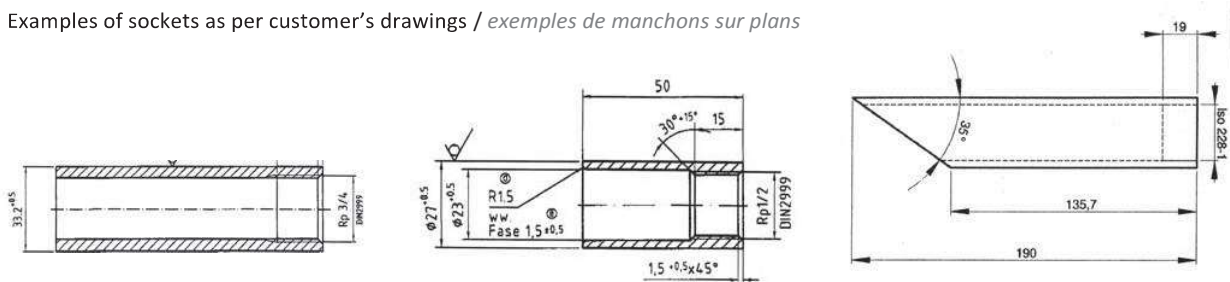

## RIGID CONDUIT COUPLINGS

### Manchons conduites électriques

Dimensions according to/suivant UL6 / ANSI C80.1  
Threads / filetages ANSI B 1.20.1



Finishing / finition

Black / noir

Electro plating / galvanisation électrolytique

NOMINAL DIAMETER IN INCH		1/8"	1/4"	3/8"	1/2"	3/4"	1"	1 1/4"	1 1/2"	2"	2 1/2"	3"	3 1/2"	4"	5"	6"
NOMINAL DIAMETER IN MM		6	8	10	15	20	25	32	40	50	65	80	90	100	125	150
 RIGID CONDUIT COUPLING JD 110	Diameter in mm	X	X	X	25,7	31,8	38,7	47,5	54,7	67,3	82,6	98,3	114,3	123,8	152,4	182,9
	Length in mm	X	X	X	41,27	41,7	50	51,6	52,4	54	81	84,1	86,5	89,3	100,4	108
	ANSI B1.20.1															
	UL 6/ANSI C.80.1															

Base materials: special Delcorte socket tubing / seamless pipes

Matières de base : tubes à manchons suivant spécification Delcorte / tubes sans soudure

## CONDUIT COUPLINGS FOR ELECTRICAL WIRING

### Manchons conduites électriques

Dimensions according to/suivant EN standards

Threads / filetages : EN standards

Finishing / finition

Black / noir

Hot dip galvanising / galvanisation à chaud

Electro plating / galvanisation électrolytique

NOMINAL SIZE		16	20	25	32	40	50	63
 COUPLING JD 109	Diameter in mm	18	22	28	35	44	55	68
	Length in mm	30	33	39	43	50	55	60
	Metric Thread 1,5mm							
	EN 60423/94							

Half coupling on request

NOMINAL SIZE		1/2"	5/8"	3/4"	1"	1" 1/4	1" 1/2	2"	2" 1/2
 COUPLING JD 108	Diameter in mm	15	18	21,5	28	35	42,5	55	69
	Length in mm	26	29	32	38	42	45	51	58
	BS 31								

NOMINAL SIZE		9	11	13	16	21	29	36	42	48
 COUPLING JD 107	Diameter in mm	17	20,5	23	25	31	41	51	59	65
	Length in mm	26	30	30	36	40	44	54	60	64
	DIN 40430									
	DIN 49020									

## PROFILE SOCKETS FOR SPRINKLER SYSTEMS

### Manchons grugés pour installations anti-feu

Available thread types: BSP and NPT  
 Taraudages disponibles : BSP et NPT

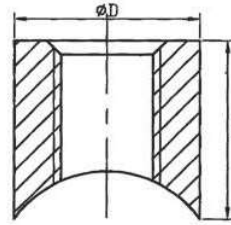

Socket size

Dimension du manchon

Socket sizes / Manchons	OD	inch	1/2"	3/4"	1"	1 1/4"	1 1/2"	2"	2 1/2"
		nom	15	20	25	32	40	50	65
		mm	26,6	33,3 <sup>a</sup>	40	49,25	56,3	69,5	84,4
Base lengths options mm		23	23	27	35	35	45	65	
		34	36	43	On request sur demande	On request sur demande	On request sur demande	On request sur demande	
OD inch nom		Other base lengths on request / autres longueurs sur demande							
Run pipe size / tube porteur <sup>b</sup>	1"	25	15 x 25	20 x 25	On request sur demande				
	1 1/4"	32	15 x 32	20 x 32	25 x 32	On request sur demande			
	1 1/2"	40	15 x 40	20 x 40	25 x 40	32 x 40	On request sur demande		
	2"	50	15 x 50	20 x 50	25 x 50	32 x 50	On request sur demande	On request sur demande	
	2 1/2"	65	15 x 65	20 x 65	25 x 65	32 x 65	40 x 65	50 x 65	On request sur demande
	3"	80	15 x 80	20 x 80	25 x 80	32 x 80	40 x 80	50 x 80	65 x 80
	4"	100	On request sur demande	20 x 100	25 x 100	32 x 100	40 x 100	50 x 100	65 x 100
	6"	150	On request sur demande	On request sur demande	25 x 150	32 x 150	40 x 150	50 x 150	65 x 150

a: alternatively, OD 32mm available on request / diamètre extérieur 32 mm disponible sur demande  
 b: run pipe sizes of 8" and above on request / tube porteur 8" et plus sur demande

## PROFILE TUBULAR GROVED OR THREADED

### Bobines grugées rainurées ou filetées

Available thread types: BSP and NPT  
 Taraudages disponibles: BSP et NPT



Grooved and profile pipe piece  
 Bobine rainurée

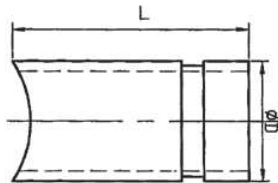

Profile threaded nipple  
 bobine filetée

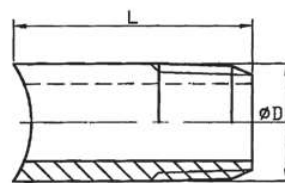

Size

Dimension

OD inch	1/2"	3/4"	1"	1 1/4"	1 1/2"	2"	2 1/2"	3"
OD nom	15	20	25	32	40	50	65	80
OD mm	21,3	26,9	33,7	42,4	48,3	60,3	76,1/73c	88,9
Length <sup>a</sup>	80	80	80	80	80	80	80	80
Run Pipe inch	3/4" - 4"	1" - 4"	1 1/4" - 6"	1 1/2" - 6"	2" - 6"	2 1/2" - 6"	3" - 8"	4" - 8"
Run Pipe mm	20-100	20-100	32-150	40-150	50-150	65-150	80-200	100-200
Threads <sup>b</sup>	BSP/NPT	BSP/NPT	BSP/NPT	BSP/NPT	BSP/NPT	BSP/NPT	BSP/NPT	BSP/NPT

a: other lengths on request / autres longueurs sur demande  
 b: for threaded nipples / concerne les bobines filetées  
 c: 73mm OD for ASME pipes / diamètre 73mm pour les tubes suivant ASME



## IV. TECHNICAL INFORMATION

### INFORMATIONS TECHNIQUES

**Materials requirements / pressure rating / standard & length of threads / dimensions of SW fittings, weight list / pipe dimensions**

*Spécifications matières / pression de service / longueur et standard de filetage / dimensions des raccords à souder / liste de poids / dimensions de tube*



**MATERIALS REQUIREMENTS - SPÉCIFICATIONS MATIÈRES.....65-66**

**PRESSURE RATING - PRESSION DE SERVICE ..... 67**

**WORKING PRESSURE TEMPERATURE RATING - PRESSION ET TEMPÉRATURES DE SERVICE ..... 68**

**REDUCED TEES AND CROSSES - TÉS ET CROIX RÉDUITS ..... 69**

**LENGTH OF THREAD - LONGUEUR DE FILETAGE ..... 69**

**STANDARD TAPER PIPE THREAD (NPT) - FILETAGE CONIQUE POUR TUBES (NPT) ..... 70**

**DIMENSIONS OF SOCKET WELDING FITTINGS - DIMENSIONS DES RACCORDS À SOUDER ..... 71**

**WEIGHT LIST IN KG/PC - LISTE DE POIDS EN KG/PC..... 72-73**

**PIPE DIMENSIONS AS PER ANSI B36.10 - DIMENSIONS DU TUBE SELON ANSI B36.10 ..... 74**



- 1 Burst test
- 2 Corrosion test
- 3 Profile projector
- 4 PMI
- 5 Tensile test



## MATERIAL REQUIREMENTS

### Spécifications matières (non exhaustive)

	TYPE	Carbon steel / acier au carbone			Alloy steel / acier allié					
	ASTM	A105/ A105M	A350/ A350 M LF1	A350/ A350 M LF2	A182/ A182 M F5	A182/ A182 M F11- CL2	A182/ A182 M F22- CL3	A182/ A182 M F9	A182/ A182 M F91	A350/ A350 M LF3
Specifications	ANSI	1020	1030	-	501	-	-	-	-	-
	UNS designation	K03504	K03009	K03011	K41545	K11572	K21590	K90941	K90901	K32025
	AFNOR (1)	A48CP	A42AP	A48FP	Z10 CD 5-05	15 CD 3-5	10 CD 9-10	Z12 CD 9-1	Z10 CD 9-1	12N14
	British standard	221	224-430	224-490	625	621	622	-	-	503
	BS 1503-1980 (1)	490	LT 40	LT 50	590	460	560	-	-	490
	DIN (1)	C 35	A St 41	St 45 N	12 Cr Mo 19-5	13 Cr Mo 4-4	10 Cr Mo 9 - 10	X12 Cr Mo 9 - 1	X10 Cr Mo V Nb 9 - 1	10 Ni - 14
Compositions chimiques - chemical composition %	Carbone	≤	≤	≤	≤	0,10	0,05	≤	0,08	≤
	Carbon	0,35	0,30	0,30	0,15	0,20	0,15	0,15	0,12	0,20
	Manganèse	0,6	≤	≤	0,30	0,30	0,30	0,30	0,30	≤
	Manganese	1,05	1,35	1,35	0,60	0,80	0,60	0,60	0,60	0,90
	Soufre	≤	≤	≤	≤	≤	≤	≤	≤	≤
	Sulphur	0,050	0,040	0,040	0,030	0,040	0,040	0,030	0,010	0,040
	Phosphore	≤	≤	≤	≤	≤	≤	≤	≤	≤
	Phosphorous	≤ 0,040	0,035	0,035	0,030	0,040	0,040	0,030	0,020	0,035
	Silicium	≤	0,15	0,15	≤	0,50	≤	0,50	0,20	0,20
	Silicon	0,035	0,30	0,30	0,50	1,00	0,50	1,00	0,50	0,35
	Chrome	-	≤	≤	4,00	1,00	2,00	8,00	8,00	≤
	Chromium	-	0,30	0,030	6,00	1,50	2,50	10,00	9,50	0,030
	Nickel	-	≤	≤	≤	-	-	-	≤	3,25
	Nickel	-	0,40	0,40	0,50	-	-	-	0,40	3,75
	Molybdène	-	≤	≤	0,44	0,44	0,87	0,90	0,85	≤
	Molybdenum	-	0,12	0,12	0,65	0,65	1,13	1,10	1,05	0,12
	Cuivre	-	≤	≤	-	-	-	-	-	≤
	Copper	-	0,10	0,10	-	-	-	-	-	0,10
	Vanadium	-	≤	≤	-	-	-	-	0,18	≤
	Vanadium	-	0,40	0,40	-	-	-	-	0,25	0,40
Niobium + Tantale	-	≤	≤	-	-	-	-	0,06 *	≤	
Colombium+Tantalum	-	0,05	0,05	-	-	-	-	0,10 *	0,05	
Titane	-	-	-	-	-	-	-	≤	-	
Titanium	-	-	-	-	-	-	-	0,01	-	
Nitrogen	-	-	-	-	-	-	-	0,03	-	
Nitrogen	-	-	-	-	-	-	-	0,07	-	
Aluminium	-	-	-	-	-	-	-	0,02 Max	-	
Aluminium	-	-	-	-	-	-	-	0,01 Max	-	
Zirconium	-	-	-	-	-	-	-	-	-	
Zirconium	-	-	-	-	-	-	-	-	-	
Caractéristiques mécaniques	Rm N/mm <sup>2</sup>	≥	415	465	≥	≥	≥	≥	≥	485
		485	à 585	à 655	485	485	515	585	585	à 655
	Rp 0,2 N/mm <sup>2</sup>	≥	≥	≥	≥	≥	≥	≥	≥	≥
		250	205	250	275	275	310	380	415	259
	A% mini - ASTM	22	25	22	20	20	20	20	20	22
	Striction % mini	30	38	30	35	30	30	40	40	35
	Dureté Brinll-HB maxi	187	197	197	143-217	143-207	156-207	179-217	248	197
	Résil. KCV à tempera. C°	-	-28,9	-45,6	-	-	-	-	-	-101,1
Moyenne J	-	≥ 18	≥ 20	-	-	-	-	-	≥ 20	
Minimum J	-	≥ 14	≥ 16	-	-	-	-	-	≥ 16	
Mechanical properties	Tensile strength (min.) 1000 psi	70	60 to 85	70 to 95	70	70	75	85	85	70 to 95
	Yield stre. (min) 1000 psi	36	30	36	40	40	45	55	60	37,5
	Elong. in 2" (min) percent	22	25	22	20	20	20	20	20	22
	Reduction of area min percent	30	38	30	35	30	30	40	40	35
	Hardness HB max.	187	197	197	143 - 217	143 - 207	156 - 207	179 - 217	248	197
	Impact test temperat. F °	-	-20	-50	-	-	-	-	-	-150
	average	-	≥ 13	≥ 15	-	-	-	-	-	≥ 15
	CHARPY V	-	≥ 10	≥ 12	-	-	-	-	-	≥ 12

# MATERIALS REQUIREMENTS

## Spécifications matières

Specifications	TYPE	Acier au chrome nickel / stainless steel										Acier inoxydable austéno-ferritique / ferritic-austenitic stainless steel		
	ASTM	A182/A182 M F304L	A182/A182 M F316L	A182/A182 M F321	A182/A182 M F347	A182/A182 M F304 H	A182/A182 M F316 H	A182/A182 M F317L	A182/A182 M F321 H	A182/A182 M F347 H	A182/A182 M F44	A182/A182 M F51	A182/A182 M F53	
	ANSI	304 L	316 L	321	347	304 H	316 H	317 L	321 H	347 H	F 44	-	-	
	UNS designation	S30403	S31603	S32100	S34700	S30409	S31609	S31703	S32109	S34709	S31254	S31803	S32750	
	AFNOR (1)	Z3 CN 18-10	Z3 CND 17-12	Z6 CNT 18-10	Z3 CNNb 18-10	Z6 CN 18-09	Z6 CND 17-12	Z3 CND 19-15-4	Z6 CNT 18-12	Z6 CNNb 18-10	Z1 CNDU 20-18-06 Az	Z3 CND 22-05-Az	Z3 CNDU 25-07-Az	
	British standard	304	316	321	347	304	316	317	321	347	-	318	-	
	BS 1503-1980 (1)	S 11	S 11	S 31	S 31	S 25	S 26	S 12	S 22	S 59	-	S 13	-	
	DIN (1)	X3 Cr Ni 18-09	X3 Cr-Ni Ni 18-10	X6 Cr Ni Ti 18-10	X6 Cr Ni Nb 18-10	X6 Cr Ni 18-10	X8 Cr Ni Mo 17-13	X2 Cr Ni Mo 18-16-4	X12 Cr Ni Ti 18-9	X6 Cr Ni Nb 18-10	X1 Cr Ni Mo Cu Ni 20-18-7	X2 Cr Ni Mo N 22-5-3	X2 Cr Ni Mo N 25-7-4	
Compositions chimiques - chemical composition %	Carbone	≤	≤	≤	≤	0,04	0,04	≤	0,04	0,04	≤	≤	≤	
	Carbon	0,030	0,030	0,08	0,08	0,10	0,10	0,030	0,10	0,10	0,020	0,030	0,030	
	Manganèse	≤	≤	≤	≤	≤	≤	≤	≤	≤	≤	≤	≤	
	Manganese	2,0	2,0	2,0	2,0	2,0	2,0	2,0	2,0	2,0	1,0	2,0	1,2	
	Soufre	≤	≤	≤	≤	≤	≤	≤	≤	≤	≤	≤	≤	
	Sulphur	0,030	0,030	0,030	0,030	0,030	0,030	0,030	0,030	0,030	0,030	0,010	0,020	0,020
	Phosphore	≤	≤	≤	≤	≤	≤	≤	≤	≤	≤	≤	≤	
	Phosphorous	0,05	0,05	0,05	0,05	0,05	0,05	0,05	0,05	0,05	0,05	0,030	0,030	0,04
	Silicium	≤	≤	≤	≤	≤	≤	≤	≤	≤	≤	≤	≤	
	Silicon	1,0	1,0	1,0	1,0	1,0	1,0	1,0	1,0	1,0	1,0	0,30	1,0	0,80
	Chrome	18,0	16,0	17,0	17,0	18,0	16,0	18,0	17,0	17,0	17	19,5	21,0	24,0
	Chromium	20,0	18,0	19,0	20,0	20,0	18,0	20,0	19,0	20	20	20,5	23,0	26,0
	Nickel	8,0	10,0	9,0	9,0	8,0	10,0	11,0	9,0	9,0	9,0	17,5	4,5	6,0
	Nickel	13,0	15,0	12,0	13,0	11,0	14,0	15,0	12,0	13,0	13,0	18,5	6,5	8,0
	Molybdène	-	2,0	-	-	-	2,0	3,0	-	-	-	6,0	2,5	3,0
	Molybdenum	-	3,0	-	-	-	3,0	4,0	-	-	-	6,5	3,5	5,0
	Cuivre	-	-	-	-	-	-	-	-	-	-	0,50	-	0,50 MAX
	Copper	-	-	-	-	-	-	-	-	-	-	1,00	-	-
	Vanadium	-	-	-	-	-	-	-	-	-	-	-	-	-
	Vanadium	-	-	-	-	-	-	-	-	-	-	-	-	-
	Niobium + Tantale	-	-	-	≥ 10 C *	-	-	-	-	-	≥ 8 C *	-	-	-
	Colombium+Tantalum	-	-	-	≥ 1,10 *	-	-	-	-	-	≤ 1,10 *	-	-	-
Titane	-	-	≥ 5 C	-	-	-	-	-	≥ 4 C	-	-	-	-	
Titanium	-	-	≤ 0,70	-	-	-	-	-	≤ 0,70	-	-	-	-	
Nitrogen	-	-	-	-	-	-	-	-	-	-	0,18	0,08	0,24	
Nitrogen	-	-	-	-	-	-	-	-	-	-	0,22	0,20	0,32	
Aluminium	-	-	-	-	-	-	-	-	-	-	-	-	-	
Aluminium	-	-	-	-	-	-	-	-	-	-	-	-	-	
Zirconium	-	-	-	-	-	-	-	-	-	-	-	-	-	
Zirconium	-	-	-	-	-	-	-	-	-	-	-	-	-	
Caractéristiques mécaniques	Rm N/mm <sup>2</sup>	≥	≥	≥	≥	≥	≥	≥	≥	≥	≥	≥	≥	
		485	485	515	515	515	515	485	515	515	650	620	800	
	Rp 0,2 N/mm <sup>2</sup>	≥	≥	≥	≥	≥	≥	≥	≥	≥	≥	≥	≥	
		170	170	205	205	205	205	170	205	205	300	450	550	
	A% mini - ASTM2	30	30	30	30	30	30	30	30	30	30	35	25	15
	Striction % mini	50	50	50	50	50	50	50	50	50	50	50	45	-
	Dureté Brinll-HB maxi	-	-	-	-	-	-	-	-	-	-	-	-	310
Mechanical properties	Résil. KCV à tempera. C°													
	Moyenne J	-	-	-	-	-	-	-	-	-	-	-	-	
	Minimum J	-	-	-	-	-	-	-	-	-	-	-	-	
	Tensile strength (min.) 1000 psi	70	70	75	75	75	75	70	75	75	94	90	116	
	Yield stre. (min) 1000 psi	25	25	30	30	30	30	25	30	30	44	65	80	
	Elong. in 2" (min) percent	30	30	30	30	30	30	30	30	30	35	25	15	
	Reduction of area Min percent	50	50	50	50	50	50	50	50	50	50	45	-	
Hardness HB max.	-	-	-	-	-	-	-	-	-	-	-	-	310	
Impact test temperat. F °														
Average														
CHARPY V														

## PRESSURE RATING

### Pression de service

Correlation of fittings class with wall designation of pipe

Relation entre la série des raccords et l'épaisseur du tube

RACCORD		Tube	FITTING		Pipe
Série	Type		Class	Type	
3000 lb 6000 lb	Fileté Fileté	Sch. 160 Double extra-fort	3000 lb 6000 lb	Threaded Threaded	Sch. 160 XXS
3000 lb 6000 lb 9000 lb	A souder A souder A souder	Sch. 80 Sch. 160 XXS	3000 lb 6000 lb 9000 lb	Socket-welding Socket-welding Socket-welding	Sch. 80 Sch. 160 XXS

Pressure - temperatures rating to ANSI B 16.11 - 1966

Pression et températures de service suivant ANSI B 16.11 - 1966

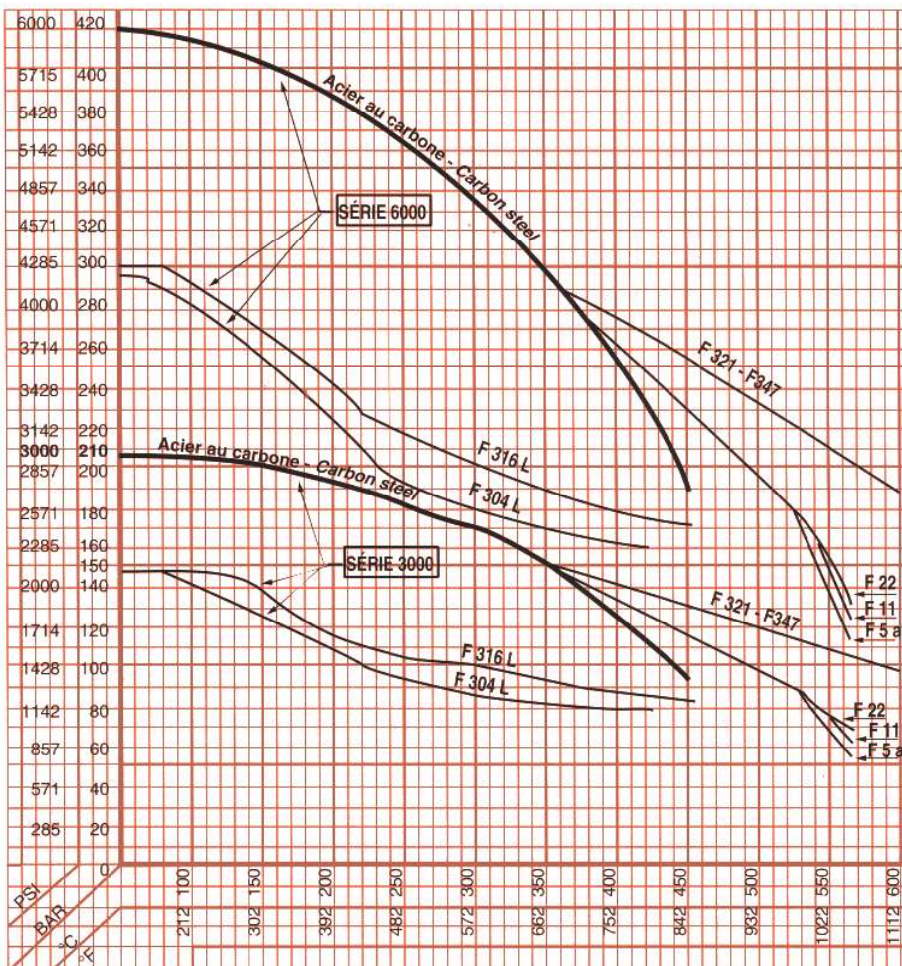

- Carbon steel ASTM A 105  
Acier au carbone A 48 CP
- Alloy steel ASTM A 182 F 5a  
Acier au carbone Molybdène Z 10 CD 5-05
- Alloy steel ASTM A 182 F 22  
Acier au chrome Molybdène 10 CD 9-10
- Alloy steel ASTM A 182 F 11  
Acier au chrome Molybdène 15 CSD 5-03-05
- Stainless steel low carbon ASTM A 182 F 304 L  
Acier inoxydable Z 2 CN 18-10
- Stainless steel carbon ASTM A 182 F 316 L  
Acier inoxydable Z 2 CND 17-12
- Stainless steel ASTM A 182 F 347  
Acier inoxydable Z 6 CN Nb 18-10
- Stainless steel ASTM A 182 F 321  
Acier inoxydable Z 6 CNT 18-10

Pressure ratings indicate non-shock working pressure of the fitting - Conditions de service valables pour travail sans coup de bélier

## WORKING PRESSURE TEMPERATURE RATING

### Pression et températures de service

#### ASTM A 105

Carbon steel according to ANSI B 16.11 - 1980

Acier au carbone suivant ANSI B16.11 - 1980

Températures		Séries - Class					
		2000		3000		6000	
°C	°F	Bar	Psi	Bar	Psi	Bar	Psi
-29 à 38	-20 to 100	137,9	2000	206,9	3000	413,8	6000
66	150	135,9	1970	203,4	2950	407,9	5915
93	200	133,8	1940	201,0	2915	402,0	5830
121	250	132,1	1915	198,3	2875	396,6	5750
149	300	130,7	1895	196,2	2845	392,4	5690
177	350	129,3	1875	193,8	2810	387,9	5625
204	400	127,6	1850	191,4	2775	382,8	5550
232	450	124,8	1810	187,2	2715	374,5	5430
260	500	119,7	1735	179,7	2605	359,3	5210
288	550	113,1	1640	169,7	2460	339,7	4925
316	600	106,2	1540	159,3	2310	318,6	4620
343	650	98,6	1430	148,3	2150	296,6	4300
371	700	90,0	1305	135,2	1960	270,3	3920
399	750	81,4	1180	122,4	1775	244,8	3550
427	800	70,0	1015	105,2	1525	210,3	3050
<b>Limite normale d'utilisation de l'acier au carbone - Normal use limit of carbon steel</b>							
454	850	57,2	830	86,2	1250	172,4	2500
482	900	42,4	615	63,8	925	127,9	1855
<b>Limite pratique d'utilisation de l'acier au carbone - Practical use limit of carbon steel</b>							
510	950	29,3	425	44,1	640	88,6	1285
538	1000	16,2	235	24,1	350	49,3	715

## REDUCED TEES AND CROSSES

### Tés et croix réduits

2 methods of designating outlets <sup>(1)</sup> - Attention... 2 possibilités <sup>(1)</sup>

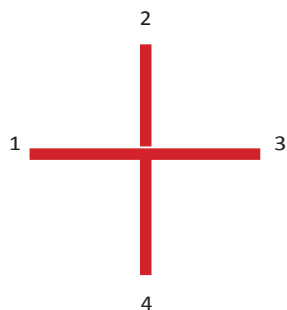

French method - *Lecture française*

Reduced crosses  
*Croix réduites*



Reduced tees  
*Tés réduits*

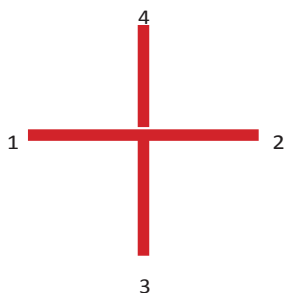

American method - *Lecture américaine*

Reduced crosses  
*Croix réduites*



Reduced tees  
*Tés réduits*

<sup>(1)</sup> Unless otherwise required we will record your orders in accordance with the American method

*Sauf spécification contraire de votre part nous enregistrons vos commandes suivant la lecture américaine*

## LENGTH OF THREAD

### Longueur de filetage

#### ASME B 16.11

Carbon steel according to ANSI B 16.11

*Acier au carbone suivant ANSI B16.11*

\* B longueur minimum du filetage parfait.

*La longueur de filetage utile ne doit pas être inférieure à L2*

Dimension B is minimum length of perfect thread.

The length of useful thread shall not be less than L2.

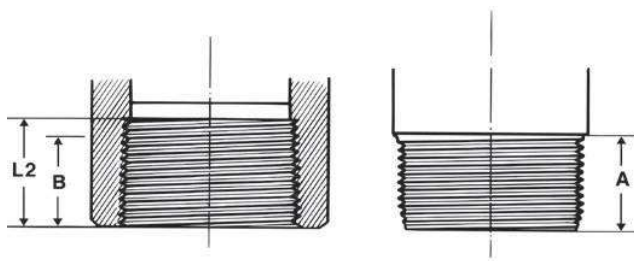

Nominal pipe size Diamètre nominal	Internal thread - Taraudage*				External thread - Filetage extérieur	
	B min.		L2 min.		A min.	
	inches	mm	inches	mm	inches	mm
1/8	0.25	6,4	0.2639	6,7	0.38	10
1/4	0.32	8,1	0.4018	10,2	0.44	11
3/8	0.36	9,1	0.4078	10,4	0.50	13
1/2	0.43	10,9	0.5337	13,6	0.56	14
3/4	0.50	12,7	0.5457	13,9	0.62	16
1	0.58	14,7	0.6828	17,3	0.75	19
1 1/4	0.67	17,0	0.7068	18,0	0.81	21
1 1/2	0.70	17,8	0.7235	18,4	0.81	21
2	0.75	19,0	0.7565	19,2	0.88	22
2 1/2	0.93	23,6	1.138	28,9	1.06	27
3	1.02	25,9	1.200	30,5	1.12	28
4	1.09	27,7	1.300	33,0	1.25	32

## STANDARD TAPER PIPE THREAD (NPT)

### Filetage conique pour tubes (NPT)

Normal engagement between male and female threads to make tight joints according to standards ANSI-B. 1.20.1 or API Std 5 B.

All the dimensions under correspond to the American standards ANSI-B. 1.20.1 and API standard 5B. Except for the nominal sizes 1/8" and 1/4", for which E1 and L1 are not measured on the same plan, according to API Std 5 B. However, the dimensions are identical when referred to the same plan.

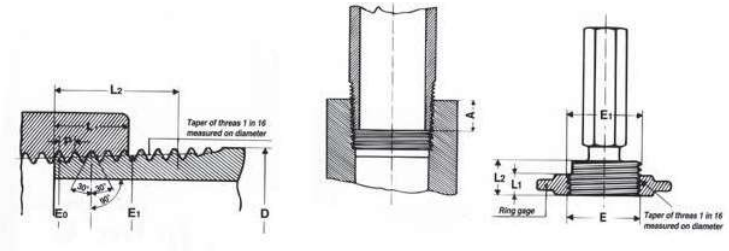

Nominal pipe size	Outside diameter of pipe D	Number of threads per inch n	Pitch of thread P	Pitch diameter at external thread end E0	Pitch diameter at internal thread end E1	Effective threads length L2	Length of hand tightening L1	Increase in diameter per thread 0.0625/n	Length of wrench tightening A
inches	inches		inches	inches	inches	inches	inches	inches	inches
1/8	0.405	27	0.03704	0.36351	0.37360	0.2639	0.1615	0.00231	0.2726
1/4	0.540	18	0.05556	0.47739	0.49163	0.4018	0.2278	0.00347	0.3945
3/8	0.675	18	0.05556	0.61201	0.62701	0.4078	0.240	0.00347	0.4067
1/2	0.840	14	0.07143	0.75843	0.77843	0.5337	3.320	0.00446	0.5343
3/4	1.050	14	0.07143	0.96768	0.98887	0.5457	0.339	0.00446	0.5533
1	1.315	11 1/2	0.08696	1.21363	1.23863	0.6828	0.400	0.00543	0.6609
1 1/4	1.660	11 1/2	0.08696	1.55713	1.58338	0.7068	0.420	0.00543	0.6809
1 1/2	1.900	11 1/2	0.08696	1.79609	1.82234	0.7235	0.420	0.00543	0.6809
2	2.375	11 1/2	0.08696	2.26902	2.29627	0.7565	0.436	0.00543	0.6969
2 1/2	2.875	8	0.12500	2.71953	2.76216	1.1375	0.682	0.00781	0.9320
3	3.500	8	0.12500	3.34062	3.38850	1.2000	0.766	0.00781	1.016
3 1/2	4.000	8	0.12500	3.83750	3.88881	1.2500	0.821	0.00781	1.071
4	4.500	8	0.12500	4.33438	4.38712	1.3000	0.844	0.00781	1.094

Engagement à la clé des filetages mâle et femelle suivant normes ANSI-B. 1.20.1 ou API Std 5 B.

Toutes les dimensions données ci-dessous correspondent aux normes américaines ANSI-B 1.20.1 ou API Standard 5 B. Excepté pour les dimensions nominales 1/8" et 1/4" où E1 et L1 ne sont pas mesurés sur le même plan d'après l'API Std 5B. Toutefois, ces dimensions ramenées sur le même plan sont identiques.

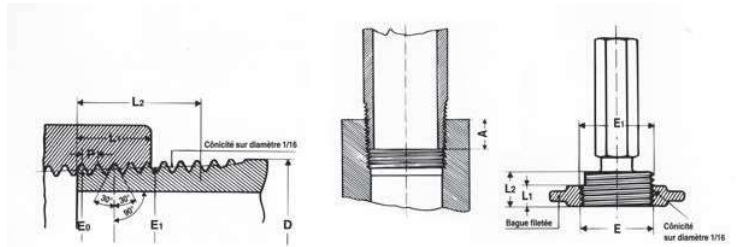

Diamètre nominal du tube	Diamètre extérieur du tube	Nombre de filets par pouce	Pas	Ø sur flancs extrémité engagem. filetage ext.	Ø sur flancs extrémité engagem. filetage int.	Longueur effective de filetage	Longueur serrage à main	Accrois. du diam. par tour	Longueur de serrage à la clé
	D	n	P	E0	E1	L2	L1		A
1/8	10,29	27	0,940	9,233	9,489	6,703	4,102	0,0586	06,9
1/4	13,72	18	1,411	12,126	12,487	10,205	5,786	0,0881	10
3/8	17,14	18	1,411	15,545	15,926	10,358	6,096	0,0881	10,3
1/2	21,34	14	1,814	19,624	19,772	13,556	8,128	0,1132	13,6
3/4	26,67	14	1,814	24,579	25,117	13,860	8,610	0,1132	14,1
1	33,40	11 1/2	2,209	30,826	31,461	17,343	10,160	0,1379	16,8
1 1/4	42,16	11 1/2	2,209	39,551	40,218	17,952	10,668	0,1379	17,3
1 1/2	48,26	11 1/2	2,209	45,621	46,287	18,377	10,668	0,1379	17,3
2	60,32	11 1/2	2,209	57,633	58,325	19,215	11,074	0,1379	17,7
2 1/2	73,02	8	3,175	69,076	70,159	28,892	17,322	0,1933	23,7
3	88,90	8	3,175	84,852	86,068	30,480	19,456	0,1933	25,8
3 1/2	101,60	8	3,175	97,472	98,776	31,750	20,853	0,1933	27,2
4	114,30	8	3,175	110,093	111,433	33,020	21,437	0,1933	27,8

## DIMENSIONS OF SOCKET WELDING FITTINGS

according to ASME B16.11

### Dimensions des raccords à souder

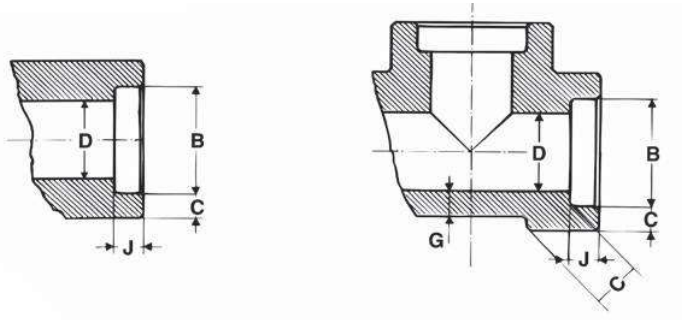

Dimensions in inches

Nominal pipe size		1/8	1/4	3/8	1/2	3/4	1	1 1/4	1 1/2	2	2 1/2	3	4	
B	Mini	0.420	0.555	0.690	0.855	1.065	1.330	1.675	1.915	2.406	2.906	3.535	4.545	
	Maxi	0.440	0.575	0.710	0.875	1.085	1.350	1.695	1.935	2.426	2.931	3.560	4.570	
D	3000 ib	Mini	0.239	0.334	0.463	0.592	0.794	1.019	1.350	1.580	2.037	2.409	3.008	3.966
		Maxi	0.299	0.394	0.523	0.652	0.854	1.079	1.410	1.640	2.097	2.529	3.128	4.086
	6000 ib	Mini	0.126	0.220	0.329	0.434	0.582	0.785	1.130	1.308	1.657			
		Maxi	0.189	0.280	0.389	0.494	0.642	0.845	1.190	1.368	1.717			
C (1)	3000 ib	Moyen	0.125	0.149	0.158	0.184	0.193	0.224	0.239	0.250	0.273	0.345	0.375	0.421
		Mini	0.125	0.130	0.138	0.161	0.168	0.196	0.208	0.218	0.238	0.302	0.327	0.368
	6000 ib	Moyen	0.156	0.181	0.198	0.235	0.274	0.312	0.312	0.351	0.430			
		Mini	0.135	0.158	0.172	0.204	0.238	0.273	0.273	0.307	0.374			
G mini.	3000 ib	0.095	0.119	0.126	0.147	0.154	0.179	0.191	0.200	0.218	0.276	0.300	0.337	
	6000 ib	0.124	0.145	0.158	0.188	0.219	0.250	0.250	0.281	0.344				
J mini.		0.38	0.38	0.38	0.38	0.50	0.50	0.50	0.50	0.62	0.62	0.62	0.75	

<sup>(1)</sup> Average of socket wall thickness around periphery shall not be no less than listed values. The minimum values are permitted in localized areas.

Dimensions en mm

Diamètre nominal		1/8	1/4	3/8	1/2	3/4	1	1 1/4	1 1/2	2	2 1/2	3	4	
B	Mini	10,80	14,20	17,60	21,80	27,20	33,90	42,70	48,80	61,20	73,90	89,80	115,20	
	Maxi	11,20	14,60	18,00	22,20	27,60	34,30	43,10	49,20	61,70	74,40	90,30	115,70	
D	3000 ib	Mini	6,10	8,50	11,80	15,00	20,20	25,90	34,30	40,10	51,70	61,20	76,40	100,70
		Maxi	7,60	10,00	13,30	16,60	21,70	27,40	35,80	41,60	53,30	64,20	79,40	103,80
	6000 ib	Mini	3,20	5,60	8,40	11,00	14,80	19,90	28,70	33,20	42,10			
		Maxi	4,80	7,10	9,90	12,50	16,30	21,50	30,20	34,70	43,60			
C (1)	3000 ib	Moyen	3,18	3,78	4,01	4,67	4,90	5,69	6,07	6,35	6,93	8,76	9,52	10,69
		Mini	3,18	3,30	3,50	4,09	4,27	4,98	5,28	5,54	6,04	7,67	8,30	9,35
	6000 ib	Moyen	3,96	4,60	5,03	5,97	6,96	7,92	7,92	8,92	10,92			
		Mini	3,43	4,01	4,37	5,18	6,04	6,93	6,93	7,80	9,50			
G mini.	3000 ib	2,41	3,02	3,20	3,73	3,91	4,55	4,85	5,08	5,54	7,01	7,62	8,56	
	6000 ib	3,15	3,68	4,01	4,78	5,56	6,35	6,35	7,14	8,74				
J mini.		9,50	9,50	9,50	9,50	12,50	12,50	12,50	12,50	16,00	16,00	16,00	19,00	

<sup>(1)</sup> La moyenne de l'épaisseur de l'emboîtement sur la périphérie ne sera pas inférieure aux valeurs indiquées. Les valeurs minimales sont autorisées sur des surfaces délimitées.

Welding dimensions required for socket-welding components

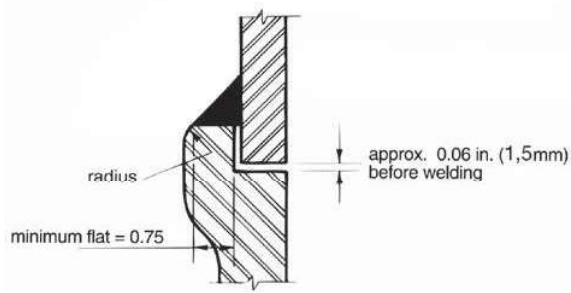

0,75 x C mini (minimum socket wall thickness)

Dimensions exigées pour la soudure d'éléments à emboîtement à souder (S.W.)

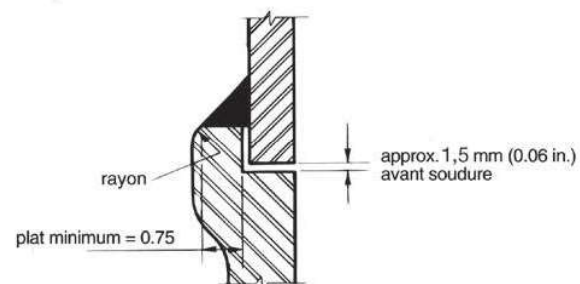

0,75 x C mini (épaisseur mini de la chambre)

## WEIGHT LIST IN KG/PC

Liste de poids en kg/pc

## THREADED

Tarudés

Threaded	Class	Item N°	1/8"	1/4"	3/8"	1/2"	3/4"	1"	1 1/4"	1 1/2"	2"	2 1/2"	3"	4"
Manchons / Couplings	3000	JD 500	0,06	0,07	0,09	0,15	0,22	0,43	0,85	1,08	1,64	2,32	3,60	6,40
	6000	JD 505	0,10	0,11	0,14	0,29	0,45	0,96	1,30	2,00	3,40	5,00	6,70	12,50
Demi-manchons / Half-couplings	3000	JD 510	0,03	0,04	0,05	0,08	0,11	0,22	0,42	0,54	0,82	1,16	1,80	3,20
	6000	JD 515	0,05	0,06	0,07	0,15	0,23	0,48	0,65	1,00	1,70	2,50	3,35	6,25
Manchons Red. / Red. Couplings	3000	JD 520		0,08	0,11	0,18	0,27	0,52	1,02	1,30	1,97	2,79	4,32	7,68
	6000	JD 525		0,13	0,17	0,35	0,60	1,16	1,56	2,40	4,08	6,00	8,04	15,00
Mamelons Hex. / Hex. Nipples	3000	JD 630	0,03	0,03	0,05	0,08	0,11	0,17	0,28	0,34	0,55	1,11	1,66	4,40
	6000	JD 635	0,04	0,05	0,10	0,15	0,21	0,35	0,45	0,55	1,00	1,80	2,50	6,20
Reductions Hex. MM / Red.H. Nipples	3000	JD 640		0,04	0,06	0,08	0,13	0,24	0,35	0,40	0,75	1,20	1,70	5,20
	6000	JD 645												
Reductions Hex. MF / HH bushings	3000/6000	JD 660		0,02	0,02	0,03	0,05	0,07	0,11	0,14	0,28	0,49	0,71	1,50
Bouchons mâles TH / HH plugs	3000/6000	JD 700	0,02	0,03	0,05	0,08	0,14	0,25	0,51	0,64	1,06	1,78	2,75	6,20
Bouchons mâles TC / SH plugs	3000/6000	JD 710	0,01	0,02	0,03	0,05	0,09	0,15	0,27	0,40	0,68	1,02	1,47	3,70
Bouchons mâles TR / RH plugs	3000/6000	JD 720	0,03	0,05	0,08	0,12	0,19	0,34	0,54	0,74	1,45	2,22	3,43	6,30
Bouchons femelles / Caps	3000	JD 730	0,03	0,04	0,06	0,12	0,16	0,28	0,51	0,73	1,30	2,25	3,33	6,42
	6000	JD 735	0,05	0,06	0,08	0,15	0,23	0,49	0,68	1,02	1,75	2,60	4,00	9,00
Coudes 90° / 90° Elbows	2000	JD 795		0,10	0,14	0,24	0,32	0,49	0,74	0,99	1,61	2,91	4,79	12,00
	3000	JD 800	0,14	0,16	0,32	0,44	0,68	1,05	1,26	2,43	3,35	5,38	8,53	17,00
	6000	JD 805	0,19	0,30	0,48	0,75	1,21	1,62	2,73	3,57	6,16	9,36	17,10	
Coudes 45° / 45° Elbows	2000	JD 835		0,09	0,12	0,20	0,28	0,42	0,62	0,78	1,32	2,61	4,26	10,20
	3000	JD 840	0,12	0,14	0,28	0,36	0,54	0,90	1,16	1,86	3,01	4,73	7,35	15,00
	6000	JD 845	0,17	0,27	0,39	0,66	1,02	1,35	2,26	3,08	5,06	7,74	14,35	
Coudes MF / Street elbows	3000	JD 850		0,11	0,18	0,25	0,42	0,65	0,94	1,42	2,17			
Tes / Tees	2000	JD 895		0,13	0,17	0,30	0,42	0,62	0,94	1,25	2,02	3,60	6,07	15,00
	3000	JD 900	0,18	0,23	0,38	0,54	0,84	1,30	1,64	2,92	4,10	6,88	10,65	19,00
	6000	JD 905	0,24	0,43	0,61	0,97	1,59	2,12	3,34	4,42	7,82	12,28	22,65	
Croix / Crosses	3000	JD 916		0,27	0,43	0,70	1,05	1,61	2,14	3,35	5,05	8,33	14,63	23,00
Unions FF / FF unions	3000	JD 950	0,25	0,33	0,42	0,54	0,66	0,80	1,37	1,96	3,62	6,71	8,85	12,00
	6000	JD 970		0,48	0,66	1,45	1,79	2,30	2,83	3,90	6,78	10,00	16,00	24,00
Unions MF / MF Unions	3000	JD 955		0,54	0,73	1,70	2,01	2,78	3,48	4,90	8,48			
Tés réduits / Red. Tees	3000	JD 901		0,35	0,40	0,62	0,85	1,50	1,85	3,13	4,10	7,40	12,00	21,00
	6000	JD 906		0,50	0,90	1,15	1,70	2,50	3,90	4,85	6,00	18,00	24,00	28,00
Bossage / Welding boss	3000	JD 541	0,06	0,07	0,08	0,14	0,20	0,34	0,55	0,60	0,77			
	6000	JD 542		0,14	0,23	0,33	0,42	0,61	1,10	1,20	1,85			

Mamelons - Nipples length 50mm	SH 80	JD 605	0,03	0,04	0,06	0,08	0,11	0,17	0,22	0,27	0,37	0,57	0,76	1,11
Mamelons - Nipples length 75mm	SH 80	JD 605	0,04	0,06	0,08	0,12	0,17	0,25	0,33	0,41	0,56	0,86	1,14	1,67
Mamelons - Nipples length 100mm	SH 80	JD 605	0,06	0,08	0,12	0,16	0,22	0,33	0,44	0,54	0,74	1,14	1,52	2,22
Conc swage Nipples	SH 80	JD 760		0,25	0,50	0,11	0,17	0,29	0,45	0,70	1,45	2,00	3,50	4,80



## WEIGHT LIST IN KG/PC

Liste de poids en kg/pc

## SOCKET WELD

Socket-weld	Class	Item N°	1/8"	1/4"	3/8"	1/2"	3/4"	1"	1 1/4"	1 1/2"	2"	2 1/2"	3"	4"
Manchons / Couplings	3000	JD 550	0,06	0,07	0,09	0,14	0,20	0,34	0,49	0,66	1,04	1,70	2,15	3,61
	6000	JD 555		0,11	0,21	0,29	0,40	0,72	0,95	1,35	2,24	3,13	4,20	7,50
Demi-manchons Half-couplings	3000	JD 560	0,06	0,07	0,10	0,16	0,23	0,38	0,63	0,80	1,24	1,90	2,45	4,16
	6000	JD 565		0,14	0,23	0,35	0,45	0,80	1,08	1,52	2,55	3,61	5,00	8,50
Manchons red. / Red. Couplings	3000	JD 570		0,08	0,11	0,17	0,27	0,40	0,60	0,80	1,25	2,04	2,58	4,33
	6000	JD 575		0,10	0,24	0,35	0,48	0,86	1,14	1,62	2,69	3,76	5,04	9,00
Bouchons femelles / Caps	3000	JD 750	0,03	0,06	0,08	0,12	0,16	0,25	0,43	0,55	0,93	1,43	2,31	4,20
	6000	JD 755		0,09	0,16	0,19	0,28	0,59	0,77	1,09	1,55	2,57	3,53	6,30
Coudes 90° 90° Elbows	3000	JD 820	0,10	0,10	0,13	0,24	0,34	0,51	0,77	1,03	1,59	2,79	4,80	14,50
	6000	JD 825		0,18	0,31	0,46	0,73	1,13	1,50	2,59	3,47	6,21	9,52	15,50
Coudes 45° 45° Elbows	3000	JD 860	0,09	0,09	0,11	0,20	0,28	0,44	0,65	0,84	1,30	2,50	4,15	12,50
	6000	JD 865		0,15	0,29	0,40	0,65	0,96	1,30	2,20	3,01	5,20	7,50	13,25
Tés / Tees	3000	JD 920	0,15	0,16	0,17	0,32	0,45	0,70	0,99	1,29	2,10	3,72	6,25	18,50
	6000	JD 925		0,23	0,48	0,62	0,99	1,51	2,03	3,42	4,50	7,82	12,50	20,00
Croix / Crosses	3000	JD 940	0,18	0,19	0,27	0,39	0,56	0,84	1,23	1,66	2,64	5,10	8,05	23,00
	6000	JD 941			0,55	0,77	1,28	1,96	2,60	4,50	5,95	10,50	15,50	25,00
Inserts	3000	JD 675		0,02	0,04	0,06	0,10	0,18	0,30	0,40	0,60			
	6000	JD 680				0,10	0,25	0,35	0,44	0,70	1,00			
Unions	3000	JD 990	0,27	0,30	0,39	0,52	0,70	1,10	1,36	1,94	2,87	6,60	8,20	13,00
	6000	JD 995				1,43	1,87	2,24	2,87	4,10	7,15			
Tés réduits / Red. Tees	3000	JD 930		0,15	0,25	0,36	0,50	0,70	1,10	1,50	2,20	7,80	9,00	13,00
	6000	JD 931			0,70	0,90	1,15	1,60	2,10	3,40	4,50	9,00	15,00	18,00
Bossage / Welding boss	3000	JD 581		0,07	0,08	0,17	0,22	0,37	0,53	0,68	0,82			
	6000	JD 582		0,14	0,23	0,30	0,52	0,92	1,10	1,30	2,00			

TECHNICAL INFORMATION  
(P.63 - P.74)

DIAM. NOM. PIPE SIZE	DIAM. EXT. OUTSIDE DIAM.		SCH. 5		SCH. 10		SCH. 20		SCH. 30		SCH. STD		SCH. 40		SCH. 60		SCH. XS		SCH. 80		SCH. 100		SCH. 120		SCH. 140		SCH. 160		SCH. XXS	
	mm	inch	mm	inch	mm	inch	mm	inch	mm	inch	mm	inch	mm	inch	mm	inch	mm	inch	mm	inch	mm	inch	mm	inch	mm	inch	mm	inch	mm	inch
1/8"	10,3	0,405	-	-	1,24	0,049	-	-	1,45	0,057	1,73	0,068	-	-	2,41	0,085	-	-	-	-	-	-	-	-	-	-	-	-	-	
1/4"	13,7	0,540	-	-	1,65	0,065	-	-	1,85	0,073	2,24	0,088	-	-	3,02	0,119	-	-	-	-	-	-	-	-	-	-	-	-	-	
3/8"	17,1	0,675	-	-	1,65	0,065	-	-	1,85	0,073	2,31	0,091	-	-	3,20	0,126	-	-	-	-	-	-	-	-	-	-	-	-	-	
1/2"	21,3	0,840	1,65	0,065	2,11	0,083	-	-	2,41	0,095	2,77	0,109	-	-	3,73	0,147	-	-	-	-	-	-	-	-	4,75	0,187	7,47	0,294		
3/4"	26,7	1,050	1,65	0,065	2,11	0,083	-	-	2,41	0,095	2,87	0,113	-	-	3,91	0,154	-	-	-	-	-	-	-	-	5,56	0,218	7,82	0,308		
1"	33,4	1,315	1,65	0,065	2,77	0,109	-	-	2,90	0,114	3,38	0,133	-	-	4,55	0,179	-	-	-	-	-	-	-	-	6,35	0,250	9,09	0,358		
1 1/4"	42,2	1,660	1,65	0,065	2,77	0,109	-	-	2,97	0,117	3,56	0,140	-	-	4,85	0,191	-	-	-	-	-	-	-	-	6,35	0,250	9,70	0,382		
1 1/2"	48,3	1,900	1,65	0,065	2,77	0,109	-	-	3,18	0,125	3,68	0,145	-	-	5,08	0,200	-	-	-	-	-	-	-	-	7,14	0,281	10,15	0,400		
2"	60,3	2,375	1,65	0,065	2,77	0,109	-	-	3,18	0,125	3,91	0,154	-	-	5,54	0,218	-	-	-	-	-	-	-	-	8,74	0,344	11,07	0,436		
2 1/2"	73,0	2,875	2,11	0,083	3,05	0,120	-	-	4,78	0,188	5,16	0,203	-	-	7,01	0,276	-	-	-	-	-	-	-	-	9,53	0,375	14,02	0,552		
3"	88,9	3,500	2,11	0,083	3,05	0,120	-	-	4,78	0,188	5,49	0,216	-	-	7,62	0,300	-	-	-	-	-	-	-	-	11,13	0,438	15,24	0,600		
3 1/2"	101,6	4,000	2,11	0,083	3,05	0,120	-	-	4,78	0,188	5,74	0,226	-	-	8,08	0,318	-	-	-	-	-	-	-	-	-	-	-	-	-	
4"	114,3	4,500	2,11	0,083	3,05	0,120	-	-	4,78	0,188	6,02	0,237	-	-	8,56	0,337	-	-	-	-	11,13	0,438	-	-	13,49	0,531	17,12	0,674		
5"	141,3	5,563	2,77	0,109	3,40	0,134	-	-	-	-	6,55	0,258	-	-	9,53	0,375	-	-	-	-	12,70	0,500	-	-	15,88	0,625	19,05	0,750		
6"	168,3	6,625	2,77	0,109	3,40	0,134	-	-	-	-	7,11	0,280	-	-	10,97	0,432	-	-	-	-	14,27	0,562	-	-	18,24	0,718	21,95	0,864		
8"	219,1	8,625	2,77	0,109	3,76	0,148	6,35	0,250	7,04	0,277	8,18	0,322	-	-	10,31	0,406	12,70	0,500	15,09	0,594	18,26	0,719	20,62	0,812	23,01	0,906	22,23	0,875		
10"	273,0	10,750	3,40	0,134	4,19	0,165	6,35	0,250	7,80	0,307	9,27	0,365	10,31	0,406	12,70	0,500	15,09	0,594	17,48	0,688	18,26	0,719	21,44	0,844	25,40	1,000	28,58	1,125	25,40	1,000
12"	323,9	12,750	3,96	0,156	4,57	0,180	6,35	0,250	8,38	0,330	9,53	0,375	10,31	0,406	14,27	0,562	17,48	0,688	19,05	0,750	21,44	0,844	25,40	1,000	28,58	1,125	33,32	1,312	25,40	1,000
14"	355,6	14,000	3,96	0,156	6,35	0,250	7,92	0,312	9,53	0,375	9,53	0,375	11,13	0,438	15,09	0,594	17,48	0,688	19,05	0,750	23,83	0,938	27,79	1,094	31,75	1,250	35,71	1,406	-	-
16"	406,4	16,000	4,19	0,165	6,35	0,250	7,92	0,312	9,53	0,375	9,53	0,375	12,70	0,500	16,66	0,656	19,05	0,750	21,44	0,844	26,19	1,031	30,96	1,219	36,53	1,438	40,46	1,593	-	-
18"	457,2	18,000	4,19	0,165	6,35	0,250	7,92	0,312	11,13	0,438	9,53	0,375	14,27	0,562	19,05	0,750	21,44	0,844	23,83	0,938	29,36	1,156	34,93	1,375	39,67	1,562	45,24	1,781	-	-
20"	508,0	20,000	4,78	0,188	6,35	0,250	9,53	0,375	12,70	0,500	9,53	0,375	15,09	0,594	20,62	0,812	23,83	0,938	26,19	1,031	32,54	1,281	38,10	1,500	44,45	1,750	49,99	1,968	-	-
22"	558,8	22,000	4,78	0,188	6,35	0,250	9,53	0,375	12,70	0,500	9,53	0,375	-	-	22,23	0,875	26,19	1,031	28,58	1,125	34,93	1,375	41,28	1,625	47,63	1,875	53,97	2,125	-	-
24"	609,6	24,000	5,54	0,218	6,35	0,250	9,53	0,375	14,27	0,562	9,53	0,375	17,48	0,688	24,61	0,969	26,19	1,031	30,96	1,219	38,89	1,531	46,02	1,812	52,37	2,062	59,51	2,343	-	-
26"	660,4	26,000	-	-	7,92	0,312	12,70	0,500	-	-	9,53	0,375	-	-	-	-	-	-	-	-	-	-	-	-	-	-	-	-	-	-
28"	711,2	28,000	-	-	7,92	0,312	12,70	0,500	15,88	0,625	9,53	0,375	-	-	-	-	-	-	-	-	-	-	-	-	-	-	-	-	-	-
30"	762,0	30,000	6,65	0,250	7,92	0,312	12,70	0,500	15,88	0,625	9,53	0,375	-	-	-	-	-	-	-	-	-	-	-	-	-	-	-	-	-	-
32"	812,8	32,000	-	-	7,92	0,312	12,70	0,500	15,88	0,625	9,53	0,375	17,48	0,688	-	-	-	-	-	-	-	-	-	-	-	-	-	-	-	-
34"	863,6	34,000	-	-	7,92	0,312	12,70	0,500	15,88	0,625	9,53	0,375	17,48	0,688	-	-	-	-	-	-	-	-	-	-	-	-	-	-	-	-
36"	914,4	36,000	-	-	7,92	0,312	12,70	0,500	15,88	0,625	9,53	0,375	19,05	0,750	-	-	-	-	-	-	-	-	-	-	-	-	-	-	-	-

PIPE DIMENSIONS AS PER ANSI B36.10  
Dimensions du tube selon ANSI B36.10



**NOTES**

A series of horizontal dashed lines for taking notes, spanning the width of the page.



Catalog product presentations including catalog dimensions, designs and specifications are representative of product availability at time of publication only. Actual geometry and designs are subject to designs and manufacturing changes without notice.

*Les présentations du catalogue qu'il s'agisse des dimensions, designs et normes sont représentatives de la disponibilité du produit au moment de la publication du catalogue. La géométrie et design des pièces sont sujets à modification par le fabricant sans préavis.*

Stenographic or clerical errors are subject to corrections

*Les erreurs de sténographie sont sujettes à correction*

Non-contractual photographs

*Photos non contractuelles*



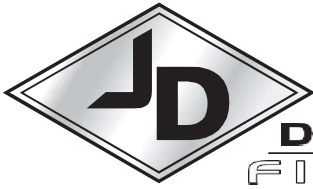

**DELCORTE**  
**FITTINGS**

- ▶ **DELCORTE FRANCE** PLANT & HEAD OFFICE  
17 rue du Corbeau - Maubeuge 59600 FRANCE  
Tel. +33 (0) 327 691 414 - Fax +33 (0) 327 691 423 - Mail: [info@delcorte.com](mailto:info@delcorte.com)  
[www.delcorte.com](http://www.delcorte.com)
- ▶ **STAFI** DISTRIBUTION GERMANY / EAST & NORTH EUROPE  
STAHLFITTINGS VERTRIEB AKTIENGESELLSCHAFT  
In der Illekatte 7-9 - 58339 BRECKERFELD - DEUTSCHLAND  
Fax +49 (0) 23 31 - 91 89 33 - Mail: [info@stafi.de](mailto:info@stafi.de)  
[www.stafi.de](http://www.stafi.de)
- ▶ **DELCORTE - SORGUES/AVIGNON**  
DISTRIBUTION FRANCE / SOUTH EUROPE  
Zone Industrielle-Avenue Bernard Palissy - 84700 SORGUES FRANCE  
Tel. +33 (0) 490 39 15 51 - Fax +33 (0) 490 83 47 69 - Mail: [stock@delcorte.com](mailto:stock@delcorte.com)
- ▶ **D.MEC** - DELCORTE MIDDLE EAST CORPORATION  
Balçık Mah. Kumtepe Mevki , 3273. Sokak No: 29 Gebze / KOCAELI, 41400 Turkey  
Tel. +90 0 262 751 21 71 72 - Fax +90 0 262 751 21 75  
[www.dmec.com.tr](http://www.dmec.com.tr)

